

# KPM I/KPM II STACK-MODE ELECTRONIC SEED MONITOR INSTALLATION INSTRUCTIONS

IS628

Rev. 6/06

Throughout these instructions the symbol  and/or the words **NOTE**, **IMPORTANT**, **CAUTION**, **WARNING** or **DANGER** are used to call your attention to important information. The definition of each of these terms follows:

**NOTE:** Indicates a special point of information or addresses a machine adjustment.

**IMPORTANT:** Indicates information which, if not heeded, could result in damage to the machine.



**CAUTION:** Indicates a potentially hazardous situation which, if not avoided, may result in minor or moderate personal injury.



**WARNING:** Indicates a potentially hazardous situation which, if not avoided, could result in death or serious personal injury.



**DANGER:** Indicates an imminently hazardous situation which, if not avoided, will result in death or serious personal injury.

Before beginning installation, read completely through these instructions.

Using the shipping order and/or the Contents Listings section at the end of these instructions, check to be sure you have all the packages needed to complete assembly.

The information used in these instructions was current at the time of printing. However, due to KINZE's continual attempts to improve its product, production changes may cause your planter to appear slightly different in detail. KINZE Manufacturing, Inc. reserves the right to change specifications or design without notice and without incurring obligation to install the same on planters previously manufactured.

Right hand (R.H.) and left hand (L.H.), as used throughout these instructions, are determined by facing in the direction the machine will travel when in use, unless otherwise stated.



**DANGER:** Always install all safety lockup devices or lower machine to the ground before working under or around the machine.

Monitor Serial No. \_\_\_\_\_

Measured Pulses Per Mile/km (Radar Distance Sensor) \_\_\_\_\_

Measured Pulses Per Mile/km (Magnetic Distance Sensor) \_\_\_\_\_

The KPM I Electronic Seed Monitor Package consists of (a) a KPM I console, which is mounted on the tractor; (b) seed tubes with sensors, one of which is installed in each planter row unit; and (c) a planter harness (junction Y-harness and/or extension harness where applicable), to which the individual seed tube sensors connect. The primary harness, which connects the monitor console to the planter harness, is included in the existing wiring harness on the planter.

The KPM II Stack-Mode Electronic Seed Monitor Package consists of (a) a KPM II Stack-Mode console, which is mounted on the tractor; (b) seed tubes with sensors, one of which is installed in each planter row unit; (c) a magnetic distance sensor, which is installed on the planter, or a radar distance sensor, which is installed on the tractor; (d) a shaft rotation sensor kit (Models 3120, 3140, 3200, 3600, 3650, 3700 and 3800 only), which is installed on the planter drill shafts; and (e) a planter harness (junction Y-harness and/or extension harness where applicable), to which the individual seed tube sensors connect. The primary harness, which connects the monitor console to the planter harness, is hard wired into the safety/warning light harness or control console harness included as standard equipment with the planter.

The software design of the KPM II Stack-Mode console allows the use of an add-on SMM console for simultaneous viewing of the seed flow bar graphs for standard and/or Interplant® System rows (up to 36 rows in two sections). A total of 72 rows may be displayed in multiple sections (rear/front, left/right or four sections). The SMM console must be used to allow utilization of the four section feature. The SMM console is included with the KPM II Electronic Seed Monitor Package for 24 and 36 row Model 3700 planters and all 3800 planters. It is available as a separate package for use when 3400, 3600 or 3650 planters are equipped with Interplant® Package rows.

The monitor is powered by the tractor battery (requires 12 volts DC).

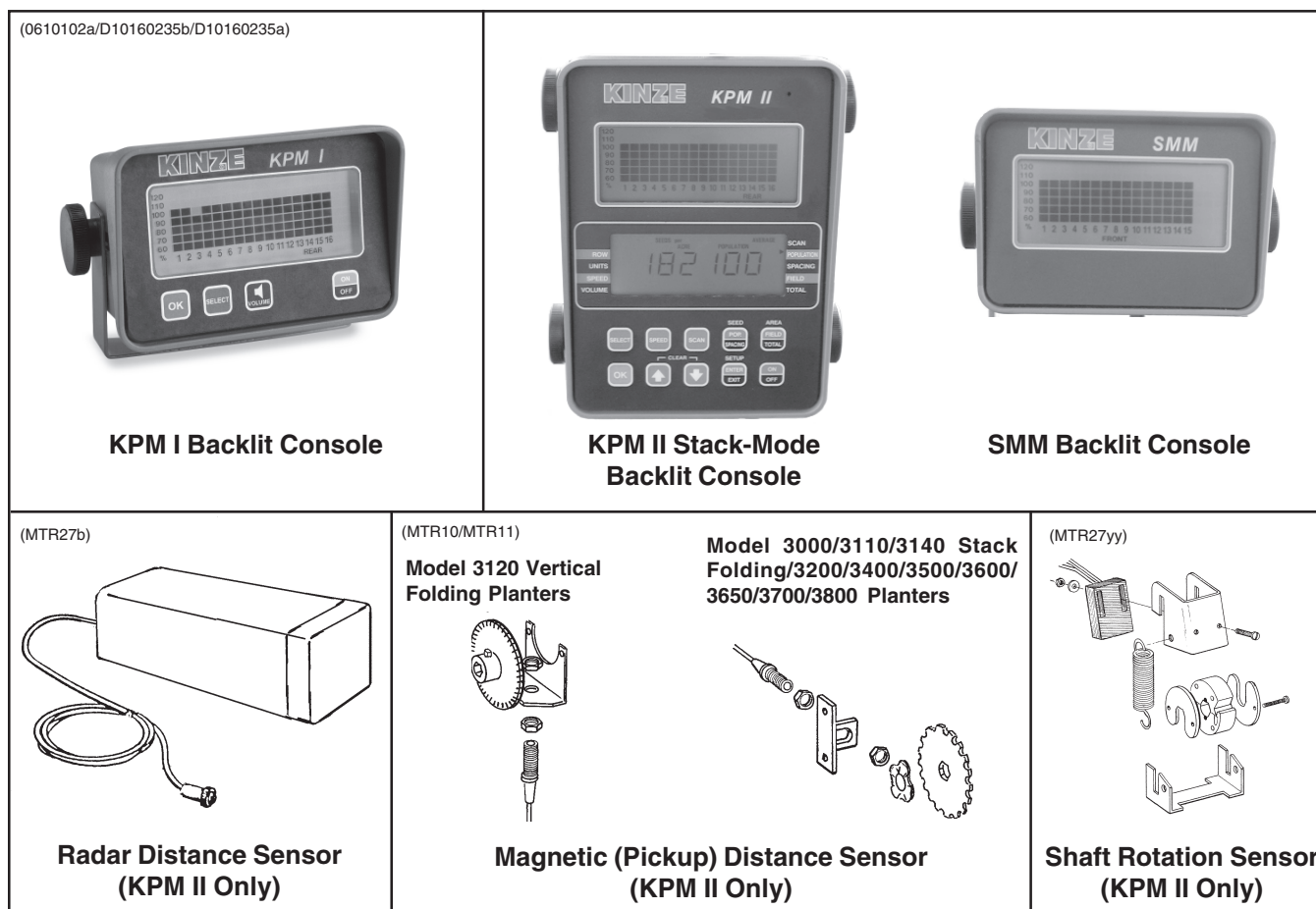

**NOTE:** If the console is not installed in the tractor at the time of planter installation, the console must be connected to a 12 volt power source before any of the planter components can be programmed when plugged into the planter harness. See “KPM I - Connecting Seed Tubes” or “KPM II - Connecting SMM Console, Shaft Rotation Sensors, Seed Tubes And/Or Radar/Magnetic Distance Sensors”.

## TRACTOR COMPONENTS INSTALLATION

STEP 1. Install Console(s) .....	4
STEP 2. Connect Power .....	5
STEP 3. Install Radar Distance Sensor (Applicable Only To KPM II Stack-Mode With Radar Distance Sensor) .....	6

## PLANTER COMPONENTS INSTALLATION

STEP 1. Install Seed Tubes Into Row Units .....	8
STEP 2. Install Drill Shaft Rotation Sensors (Applicable only to Model 3120 Vertical Folding, Model 3140 Stack Folding, Model 3200, Model 3600, Model 3650, Model 3700 and Model 3800 Planters equipped with KPM II Monitor.) .....	10
STEP 3. Install Magnetic Distance Sensor (Applicable Only To KPM II With Magnetic Distance Sensor) .....	12
STEP 4. Install Harnesses Between Console And Seed Tubes .....	13
Model 3000 .....	14
Model 3110 .....	15
Model 3120 .....	16
Model 3140 .....	18
Model 3200 .....	20
Model 3400 .....	22
Model 3500 .....	23
Model 3600 .....	24
Model 3650 .....	26
Model 3700 .....	28
Model 3800 .....	30

## KPM I - CONNECTING SEED TUBES

Introduction .....	32
Step-By-Step Procedure .....	33

## KPM II Stack-Mode - CONNECTING SMM CONSOLE, SHAFT ROTATION SENSORS, SEED TUBES AND/OR RADAR/MAGNETIC DISTANCE SENSORS

Introduction .....	36
Step-By-Step Procedure .....	38
<b>(NOTE: See "Programming - Row Spacing" in the KPM II - Operation Section of this instruction.)</b>	

## OPERATION

KPM I .....	51
KPM II Stack-Mode .....	57

CONTENTS LISTINGS .....	85
-------------------------	----

## STEP 1. Install console(s).

Install the console on the tractor where it can be easily viewed and operated but not obstruct the operator's view.

Using the U-shaped mounting bracket as a template, mark the location of the two bracket mounting holes. Drill two  $\frac{9}{32}$ " diameter holes.

(MTR12a/MTR12e)

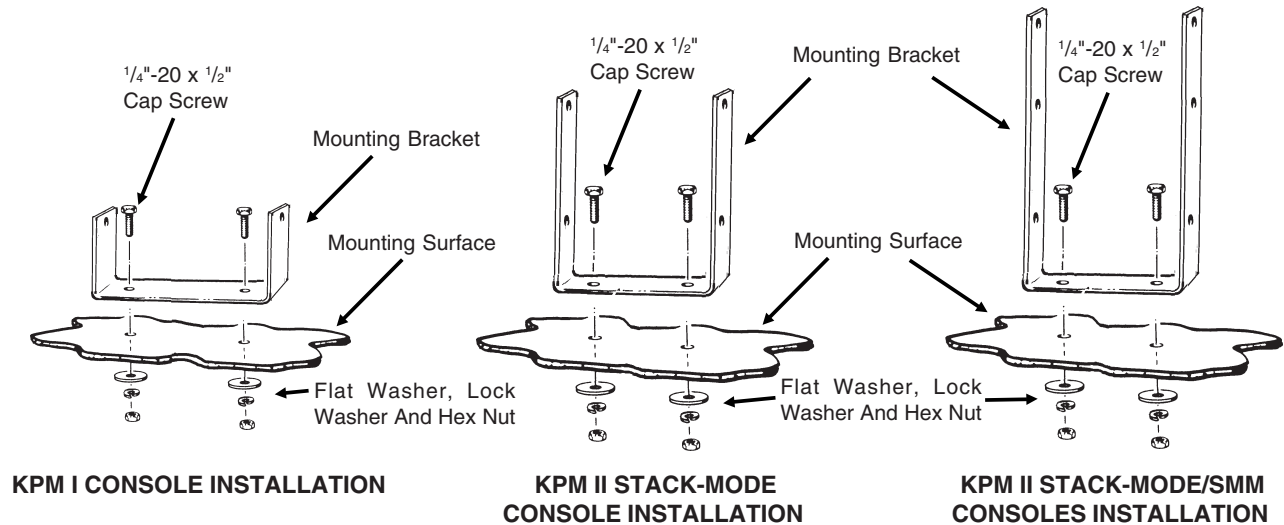

**CAUTION:** Make sure the opposite side of the drilling surface has ample clearance and is free of wiring, etc.

Attach the mounting bracket to the mounting surface using  $\frac{1}{4}$ "-20 x  $\frac{1}{2}$ " cap screws, flat washers, lock washers and hex nuts provided.

Secure console to mounting bracket using the knobs supplied. Two knobs are used with the KPM I. Four knobs are used when installing the KPM II Stack-Mode console. Six knobs are used when installing the KPM II Stack-Mode and SMM consoles. Position plastic washers between mounting bracket and console.

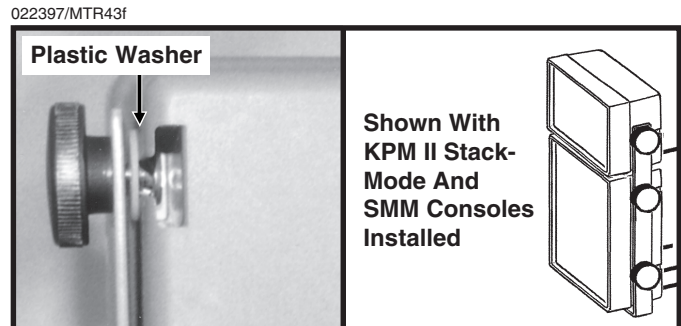

**CAUTION:** Use care when tightening the knobs. Tighten the knobs just enough to keep the console supported without slipping. **DO NOT** over tighten knobs as this could crack the monitor console sides.

Secure Quick Reference Guide supplied in monitor package to console mounting bracket.

**NOTE:** An 84" junction Y-harness (GA7853) is used to connect the SMM console to the KPM II console. **DO NOT CONNECT SMM CONSOLE TO JUNCTION Y-HARNESS UNTIL AFTER THE KPM II HAS BEEN POWERED UP.** The SMM console will go into demo mode instead of setup mode if plugged in prior to powering up the KPM II console.

**NOTE:** A 10" monitor/radar adapter (GA9144) is supplied with the KPM II Stack-Mode console for use between the console and radar distance sensor to adapt the monitor system to various tractor radar systems. **DO NOT CONNECT THE ADAPTER TO THE CONSOLE AT THIS TIME.**

## STEP 2. Connect power.

The monitor system operates on 12VDC only. The console power lead has a 3-terminal AMP CPC female connector which can be connected to the convenience outlet provided in late model tractors.

02239721



KPM I Monitor System

D091102102

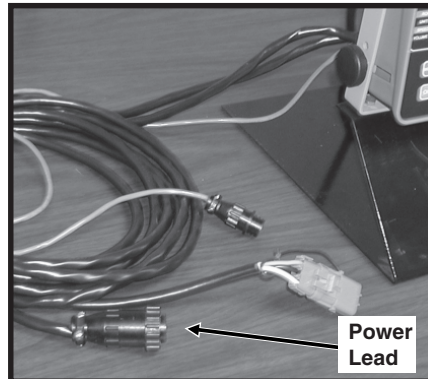

KPM II Stack-Mode Monitor System

03199703

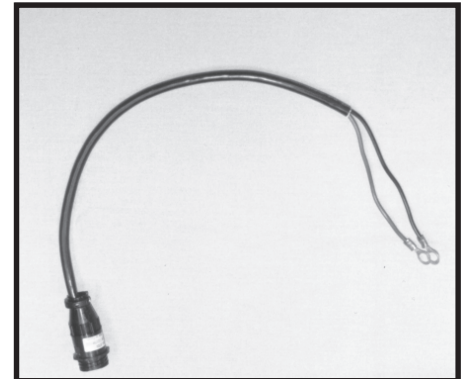

Power Lead Adapter (GA7856)

Use the optional power lead adapter (GA7856 supplied with KPM I or KPM II Stack-Mode consoles) if a two wire connection is needed. Connect the “red” wire to the positive (+) battery terminal and the “black” wire to the negative (-) battery terminal. Refer to the following illustrations for typical battery connections.

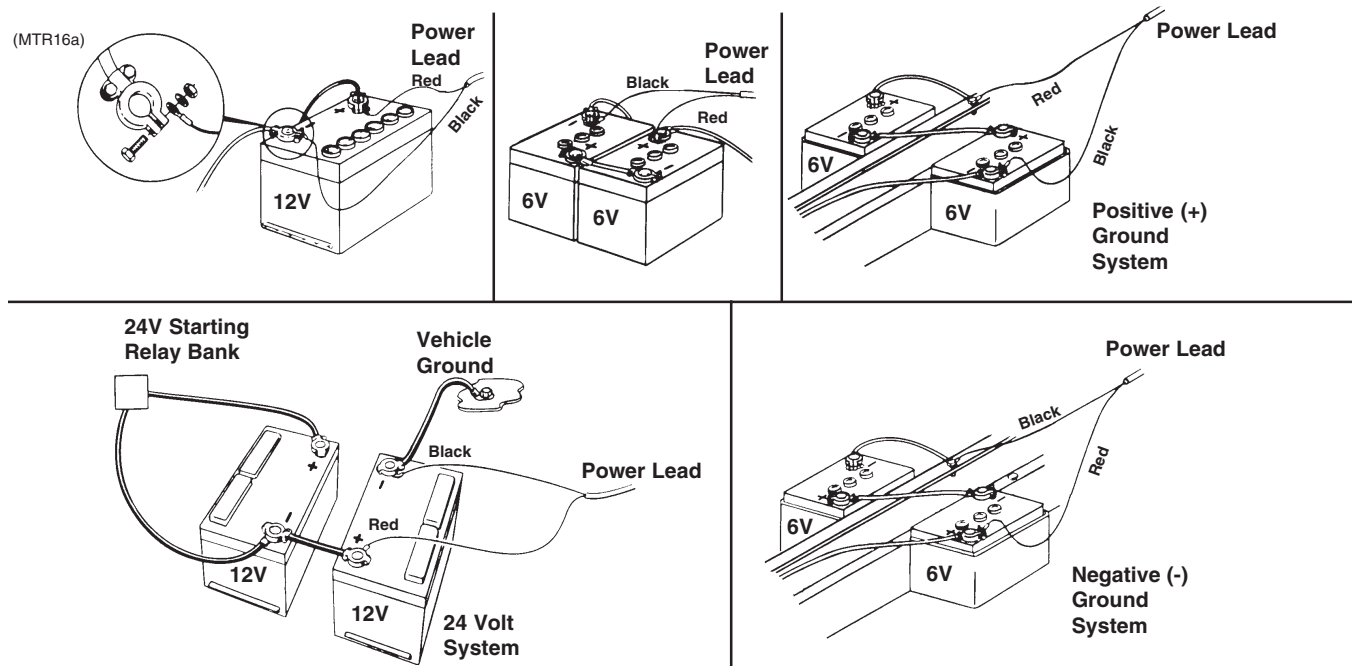

If your tractor’s battery arrangement is different than shown or if there is any question as to where to connect the power lead, use a voltmeter to make sure you measure from 11 volts to 14 volts across the “red” and “black” leads. On tractors using two 12 volt batteries, make sure console power leads are connected directly to the grounded battery.

**NOTE:** Good battery connections are essential for proper monitor operation. Make sure connections are clean and tight. If console is connected to 6 volts or condition of 12 volt battery is less than 11 volts, a continuous audible alarm will sound and the display on the monitor console will be fragmented when the ON/OFF switch is depressed.

**NOTE:** The battery, ignition and electrical system of the tractor must be in good working order.

Secure power lead with tie straps furnished with console. DO NOT route console power lead in close proximity to existing battery cables.

## STEP 3. Install radar distance sensor. (Applicable Only To KPM II Stack-Mode With Radar Distance Sensor)

- A. Install radar sensor onto mounting bracket using four 1/4"-20 x 1/2" cap screws and lock washers as shown below. Be sure cut outs in bracket are facing away from the radar sensor.

(MTR33)

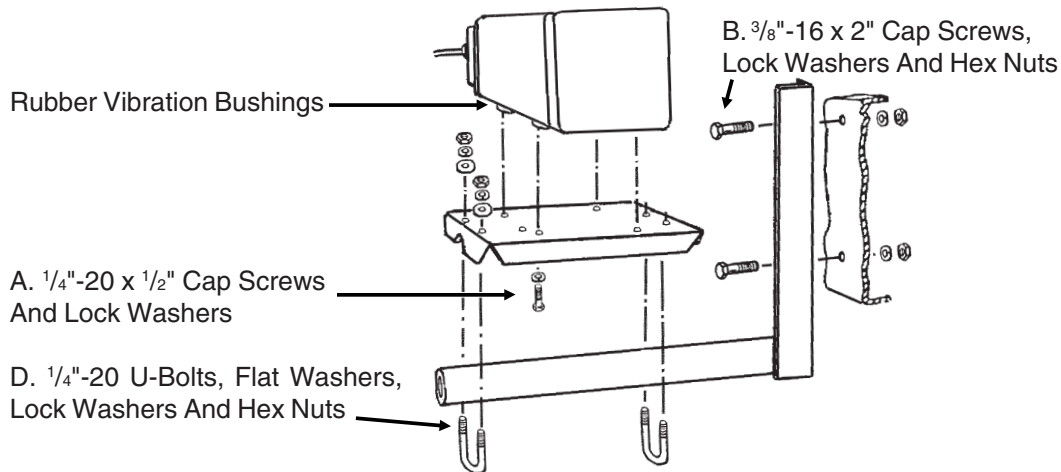

- B. Install pipe bracket onto tractor using two 3/8"-16 x 2" cap screws, lock washers and hex nuts. Prior to installation of the pipe bracket onto the tractor, read the following precautions and recommendations.

- Install the radar distance sensor approximately 2 feet above the ground.
- The radar distance sensor should be mounted facing rearward for more physical protection to the sensor.
- The radar distance sensor should not be mounted in close proximity to any major heat sources.
- The face of the radar distance sensor must have an unobstructed view of the ground.
- The radar distance sensor should be located where fluids do not drip directly on the unit.
- The mounting should offer a minimal amount of vibration potential. Excessive vibration may cause erroneous speed readings when the tractor is stationary.
- The radar distance sensor must be mounted so it "sits on top" of the rubber vibration bushings. It should not be mounted so it hangs from the rubber bushings.

- C. Drill two holes in the mounting surface and install pipe bracket.

**NOTE: Welding the bracket is not recommended in case the radar distance sensor needs to be relocated due to vibration problems.**

- D. Install radar sensor/mounting bracket onto pipe bracket using two 1/4"-20 U-bolts, flat washers, lock washers and hex nuts. Tighten the U-bolts just enough so the radar sensor can still be tipped by hand.

- E. With the tractor parked on a flat surface, place a level so it is flush on the arrowed line on the radar sensor. Tip the radar sensor until the bubble on the level is balanced at mid-line which will place the sensor at a 35° angle. Tighten the U-bolts to secure the radar sensor mounting bracket to the pipe bracket.

(MTR34)

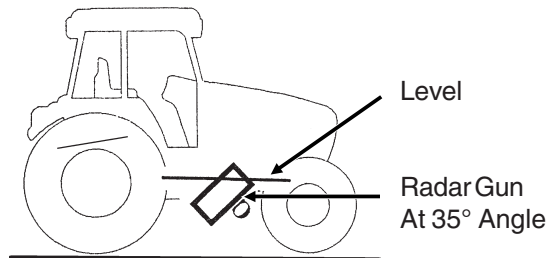

05319808

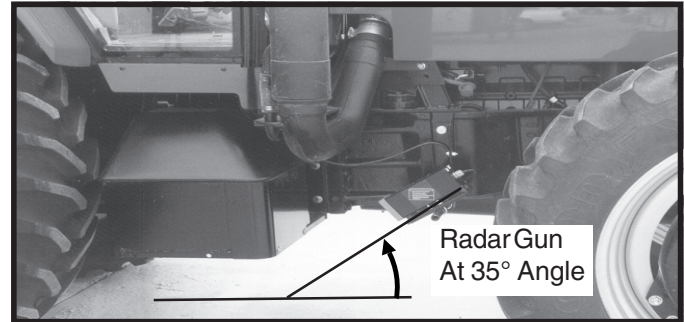

- F. Route the cable from the radar sensor to the proper location and secure with tie straps. Use care in routing cable to avoid sources of heat or areas that may pinch or damage the cable.

**IMPORTANT: DO NOT CONNECT radar distance sensor to the monitor system at this time. See “KPM II Stack-Mode - Connecting SMM Console, Shaft Rotation Sensors, Seed Tubes And/Or Radar/Magnetic Distance Sensors”.**

**NOTE: If the monitor is using the tractor's radar for ground speed input, a customer supplied Y-cable may be required to complete the installation.**

**NOTE: After installation of the radar distance sensor or any time the sensor is moved, the console must be calibrated. See “KPM II Stack-Mode Monitor, Programming Speed” in the Operation Section of the Operator & Parts Manual supplied with the planter.**

**NOTE: Excessive vibration may cause ground speed (MPH or KM/H) readings to be above zero when the tractor is stationary. To check for vibration, start tractor engine and slowly increase engine RPM (while watching the ground speed readout) to approximately 1800 RPM. If the ground speed readings are above zero, the radar distance sensor must be mounted in an alternate, more stable location.**

## STEP 1. Install seed tubes into row units.

Insert seed tube w/sensor into planter row unit shank and route the sensor lead toward the planter toolbar. Position seed tube hook over lower cross pin as illustrated below. Replace upper clevis pin through holes on upper part of seed tube assembly. Replace hair pin clip on clevis pin. Extend sensor lead toward planter toolbar as shown on the following page. Secure sensor lead to row unit with ties provided, allowing slack in lead for movement of parallel linkage.

METR55b/D01250502/RU138a

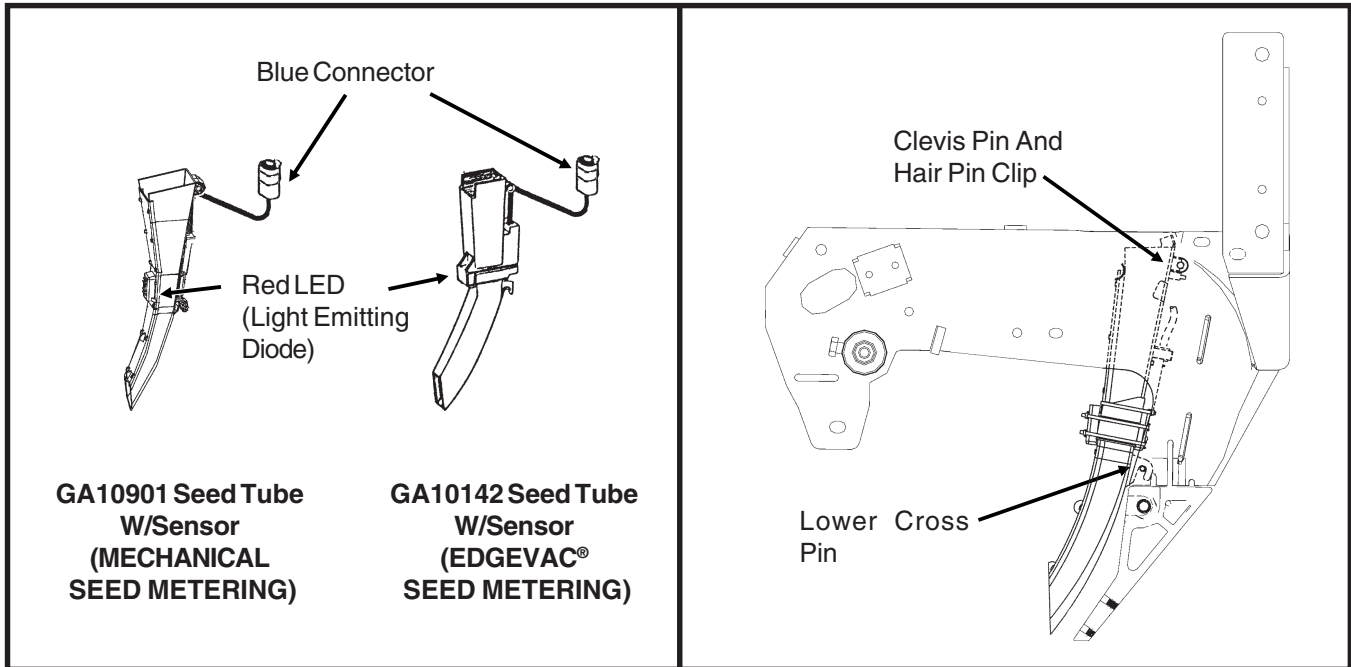

**NOTE: Make sure sensor lead cannot be damaged by parallel linkage movement or come in contact with drill shaft. DO NOT CONNECT SENSOR LEAD TO PLANTER HARNESS AT THIS TIME.**

D070799143a

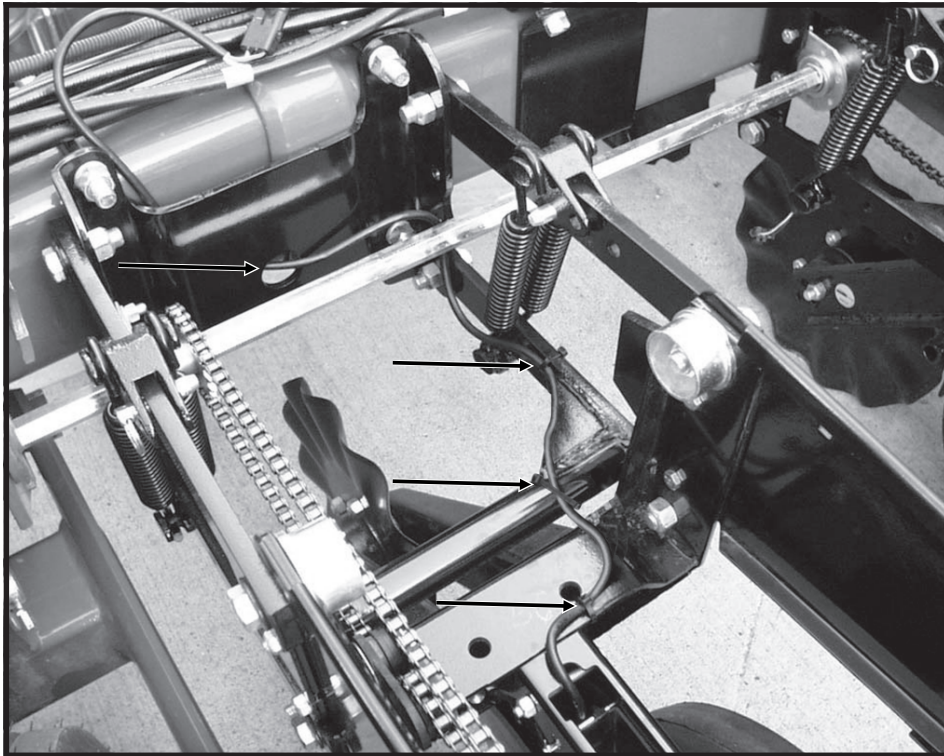

**Pull Row Unit Sensor Lead Routing**

D102700108

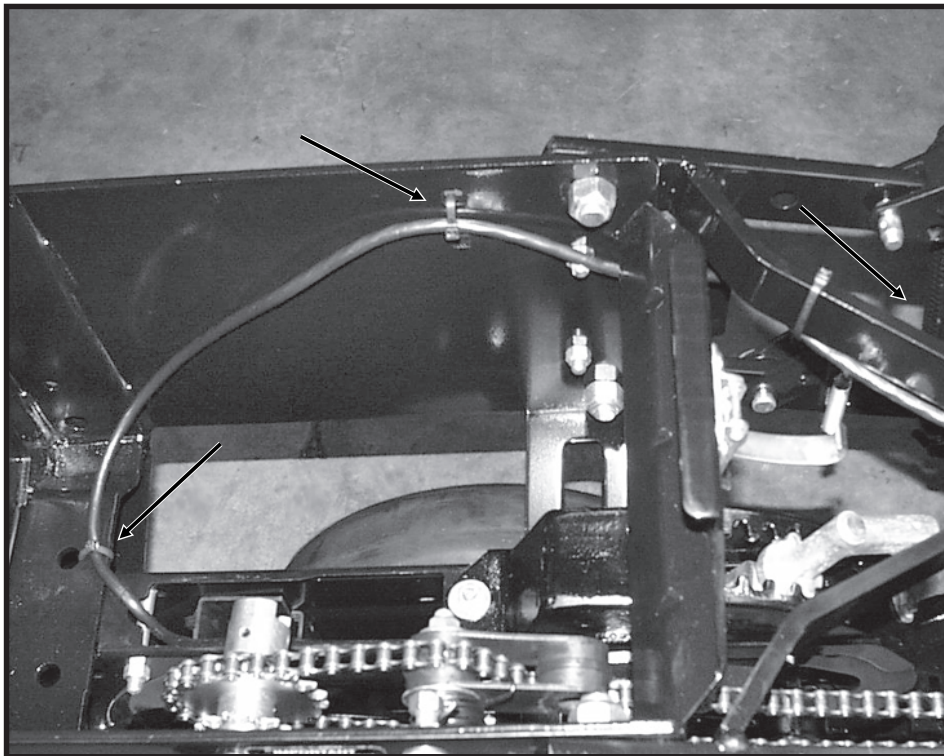

**Push Row Unit Sensor Lead Routing**

**STEP 2. Install drill shaft rotation sensors.**  
 (Applicable Only To Model 3120 Vertical Folding, Model 3140 Stack Folding, Model 3200, Model 3600, Model 3650, Model 3700 And Model 3800 Planters Equipped With KPM II Stack-Mode Monitor)

Install the drill shaft rotation sensors onto the support plates between the parallel arms of the row unit as shown in the illustrations on pages 14 through 31. In most applications the rotation sensor will be installed on the outer most row unit on each side of the planter.

**NOTE: If the row units are equipped with STYLE A frame mounted coulters, an additional support plate (left over from frame mounted coulters installation) will have to be installed between the row units on each half of the planter to allow installation of the drill shaft rotation sensors. If the row units are equipped with STYLE B frame mounted coulters, a G1K364 Rotation Sensor Mounting Kit will be required.**

(PLTR130f/RU2c)

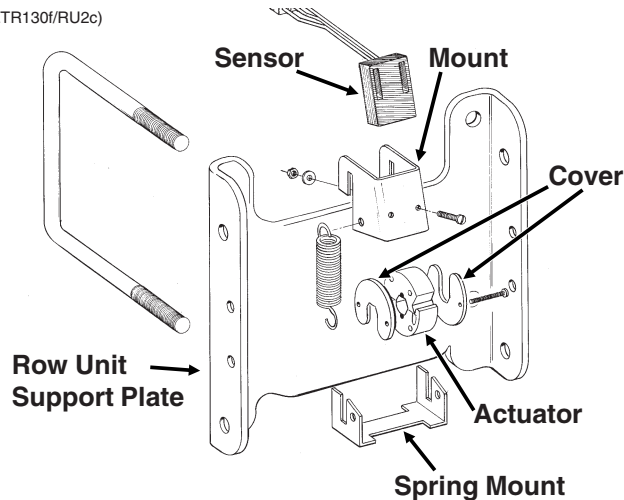

(PLTR130g)

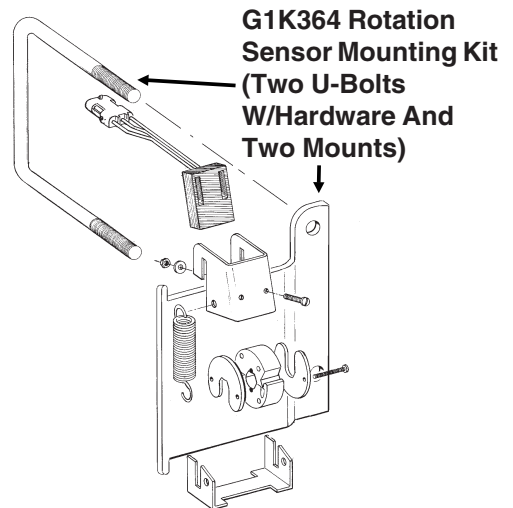

- A. Place top half of actuator over bottom half and snap the sensor actuator onto the drill shaft as shown at right.

**NOTE: DO NOT SLIDE the halves together.**

09109708

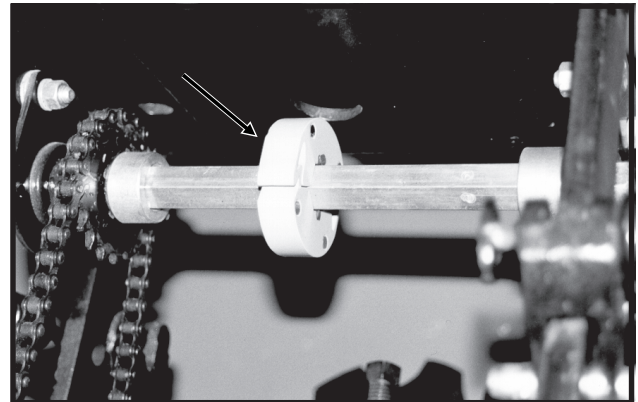

01189911

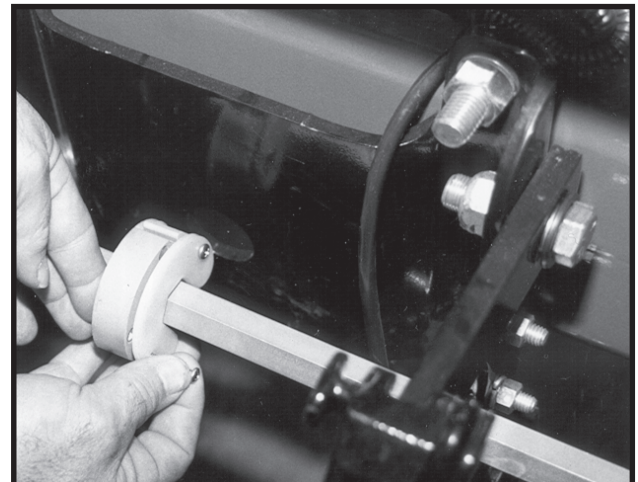

- B. Bolt plastic cover onto each side of actuator using two No. 8-32 x 1 1/4" stainless steel machine screws, lock washers and nuts. See photo at right and illustration above.

- C. Install sensor onto mount using the two No. 10 pan head screws, SAE washers and nuts as shown at right. **DO NOT** tighten screws at this time.

09109714

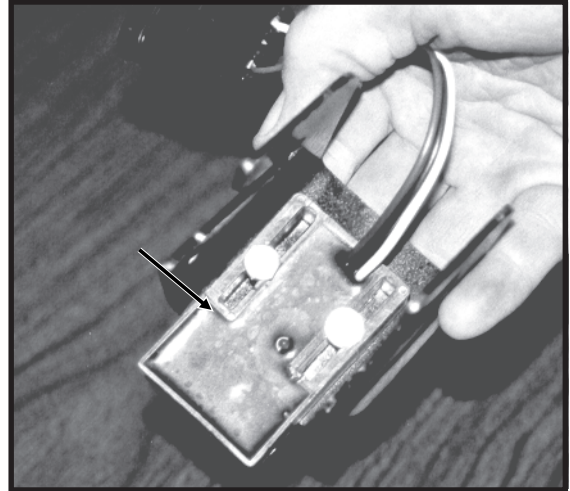

- D. Install springs onto mount as shown.

09109705

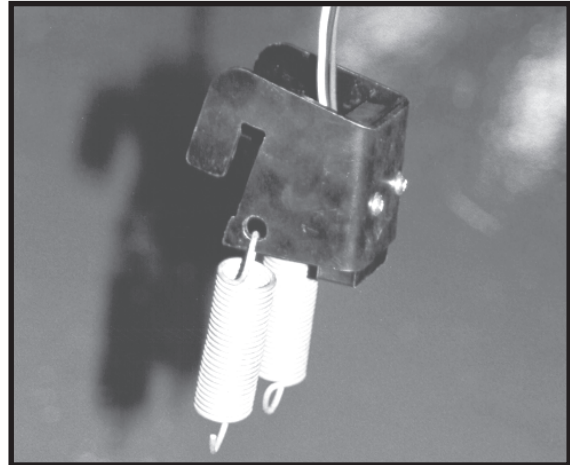

- E. Position assembly over row unit mounting support plate as shown.
- F. Position spring mount under row unit mounting support plate and connect springs as shown above.
- G. Center sensor over actuator with maximum  $\frac{1}{8}$ " gap between sensor and actuator. Tighten sensor mounting hardware.

01189905

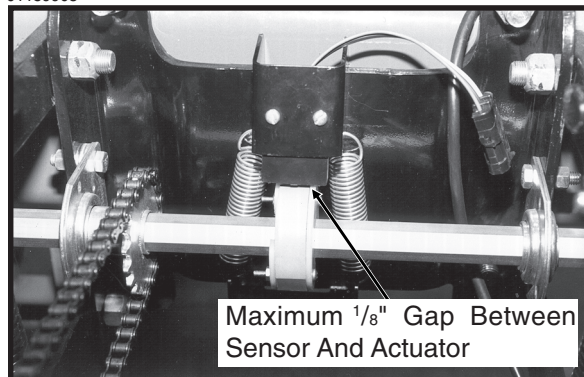

- H. Repeat Steps A through G on opposite side of planter.

**IMPORTANT: DO NOT CONNECT** drill shaft rotation sensor to the planter harness at this time. The drill shaft rotation sensors will be connected when the seed tubes are connected.

## STEP 3. Install magnetic distance sensor. (Applicable Only To KPM II Stack-Mode With Magnetic Distance Sensor)

See installation instruction supplied with **Magnetic Distance Sensor Package** (GA5606 for Model 3120 Vertical Folding Planters and GA6147 for Model 3000, 3110 Rigid, 3140 Stack Folding, 3200, 3400, 3500, 3600, 3650, 3700 and 3800 Planters) for installation of that package.

See illustrations on pages 14 through 31 for installation locations as applicable. Secure adapter with tie straps.

03199702

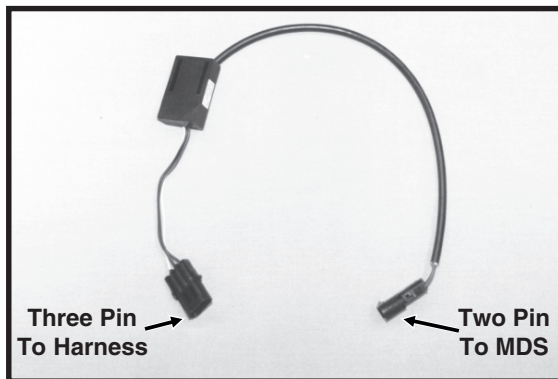

Magnetic Distance Sensor (MDS) Adapter -  
Connect To Magnetic Distance Sensor Lead

01189910

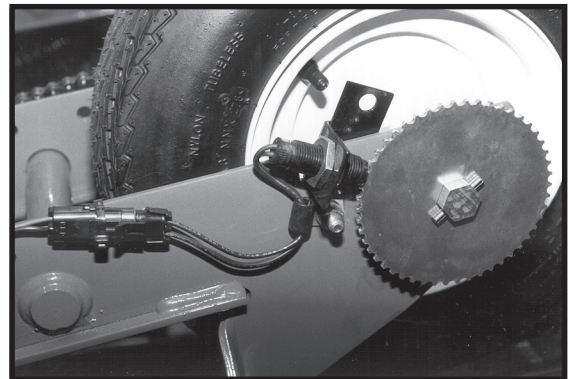

Connect MDS Adapter To MDS Lead. See Installation Instruction Supplied With MDS Package.

**IMPORTANT: DO NOT CONNECT** magnetic distance sensor adapter to the planter harness at this time.

**STEP 4. Install harnesses between console and seed tubes.**

**NOTE 1: DO NOT** connect seed tubes to harness during this step.

**NOTE 2: When installing harnesses, take care to locate each harness where it will not be pinched, cut or damaged by any moving parts during normal operation of the planter.**

Refer to the illustrations on the following pages for additional information.

- A. Lay planter harness(es) out on top of planter frame. Each planter harness will have more connectors than needed for the number of planter row units. For example, a 12 row harness will have 16 connectors and a 16 row harness will have 20 connectors. In addition to seed tube connections, one connector is used to connect the planter harness to the monitor console on the tractor. A second additional connector is used for MDS hookup (If Applicable) or for use with an optional extension harness to add an additional length of planter harness. Extra connectors may also be used to connect the drill shaft rotation sensors (If Applicable).

**NOTE: DO NOT CONNECT harness to any sensors at this time.**

- B. Connect junction Y-harness to KPM II Stack-Mode console if SMM console is being installed.

**NOTE: DO NOT CONNECT SMM CONSOLE TO JUNCTION Y-HARNESS until entering setup procedure to install sensors.**

- C. Install junction harness and/or extension harness where applicable. See the following pages for model specific installation instructions.

**NOTE: The primary harness is included in the safety/warning light wiring harness or tractor and planter control console wiring harnesses.**

- D. Connect harnesses installed in Steps A, B and C to each other.

- E. Connect console to a 12 volt power source. See STEP 2 in "Tractor Components Installation".

(MTR43I/A9152/ELC10e/ELC10d/MTR47)

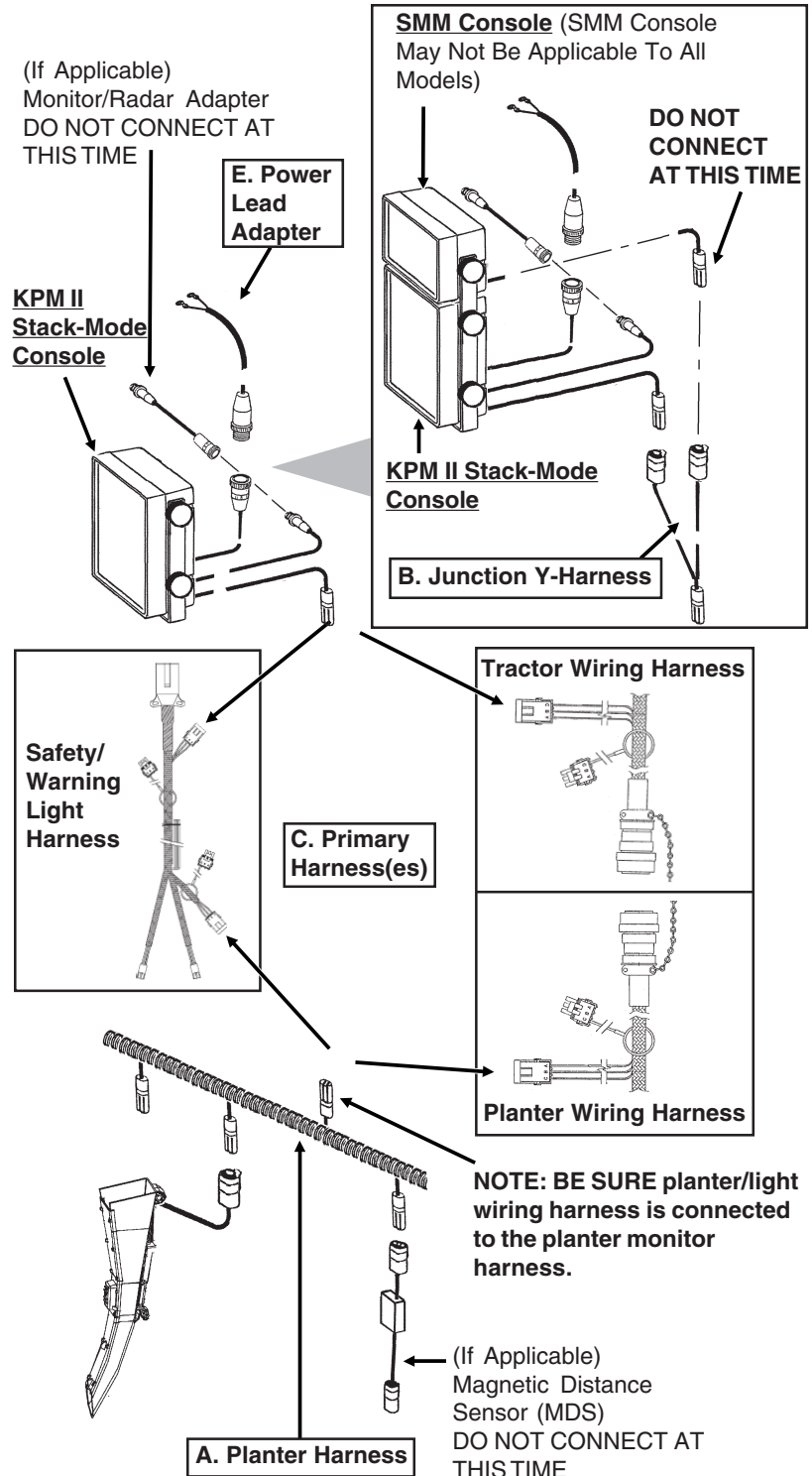

## MODEL 3000 PULL TYPE PLANTER WITH INTERPLANT® PACKAGE

(8 Row With 7 Push Row Units Shown)

(PLTR116i)

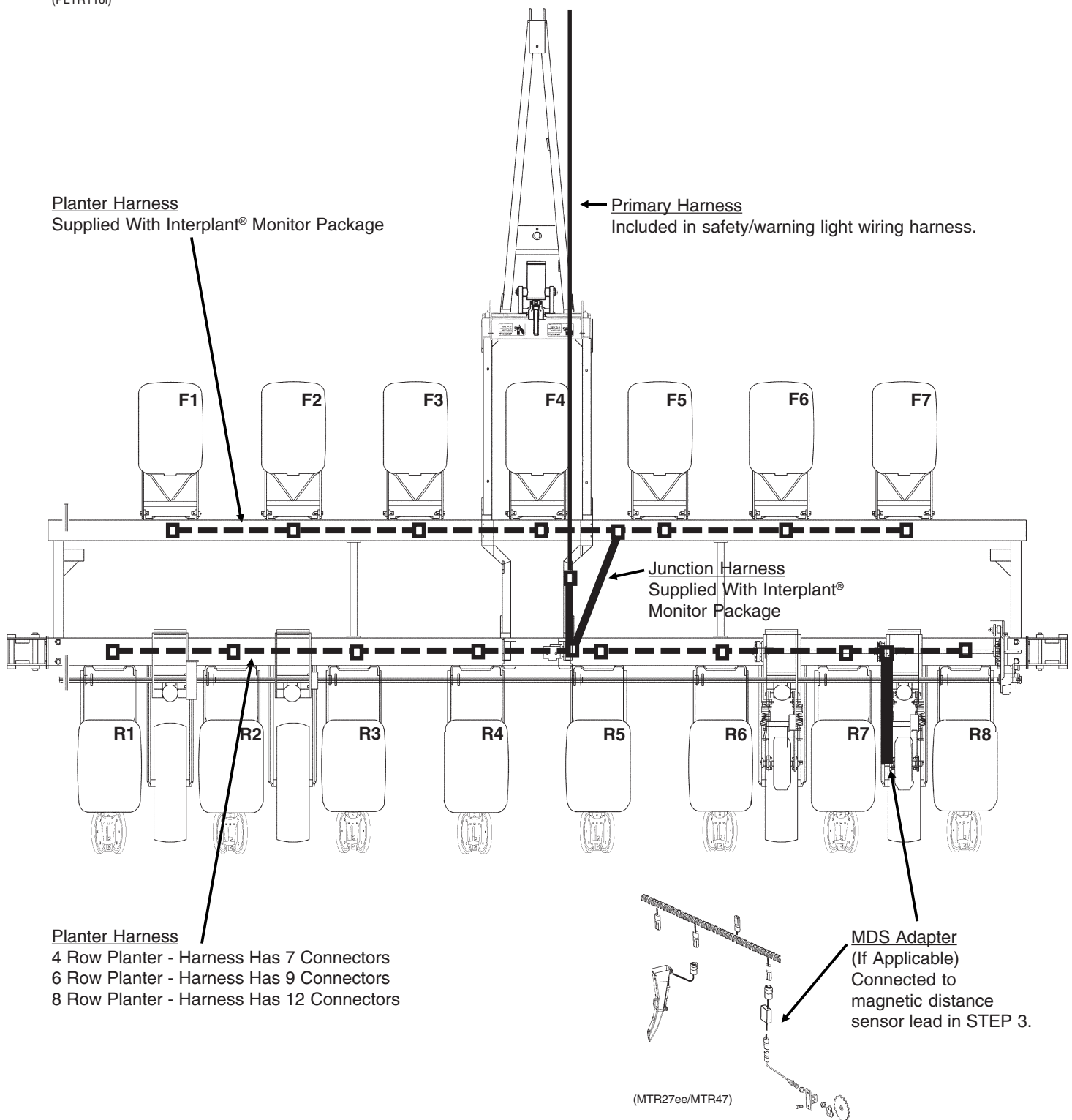

**Planter Harness**  
 4 Row Planter - Harness Has 7 Connectors  
 6 Row Planter - Harness Has 9 Connectors  
 8 Row Planter - Harness Has 12 Connectors

**NOTE:** If the radar distance sensor is being installed, it is connected to the radar sensor cable on the console and the extra connector on the planter harness is not used. If the magnetic distance sensor is being installed, it is connected to the planter harness and the sensor cable on the console is not used. Neither the radar distance sensor or the magnetic distance sensor is used with the KPM I console. Bundle and tie any unused harness connectors to the harness so they will not be damaged. **DO NOT** connect distance sensor or seed tubes at this time.

## MODEL 3110 3 POINT MOUNTED PLANTER (Rigid Frame)

(8 Row Shown)

(PLTR117h)

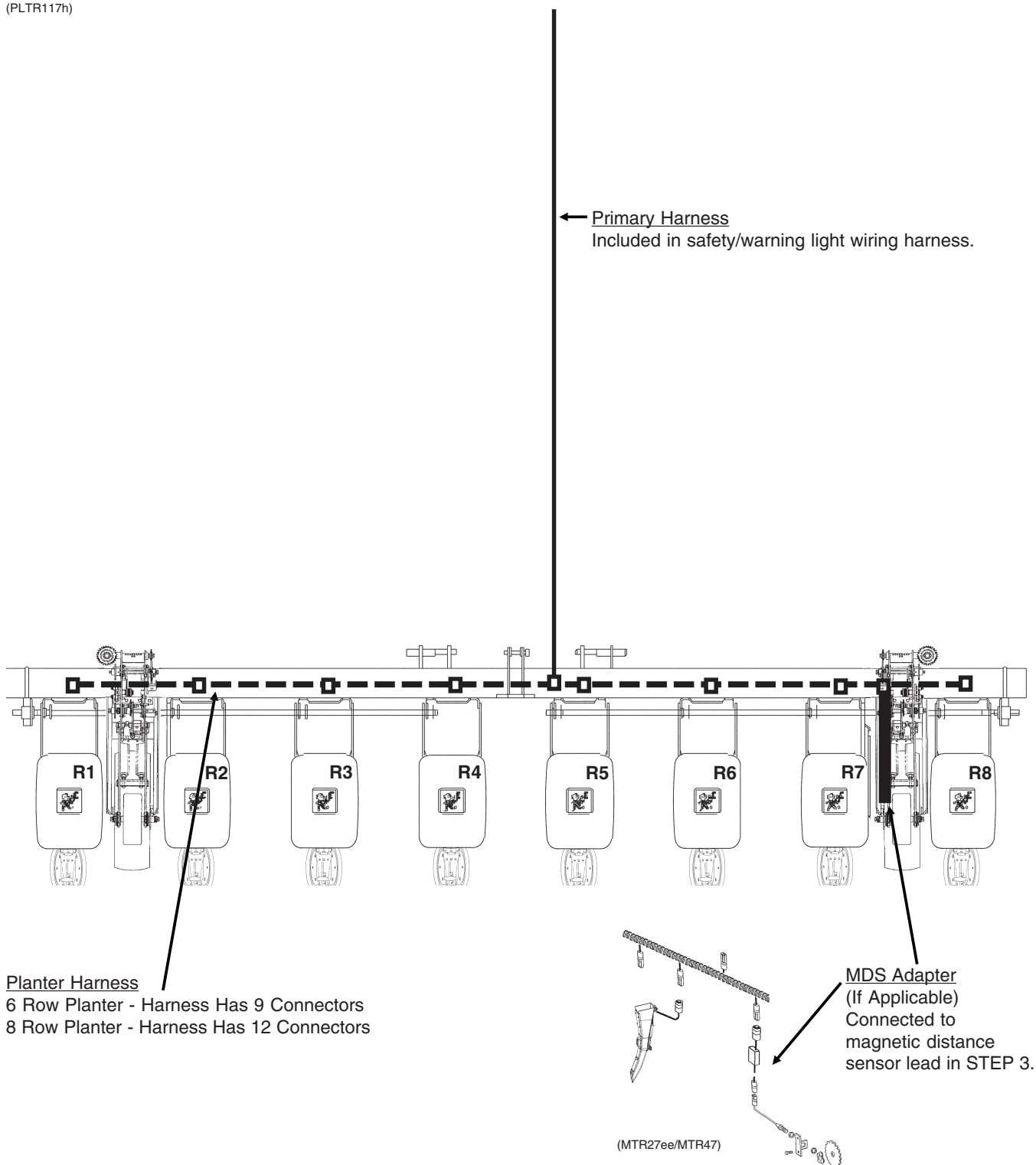

**NOTE:** If the radar distance sensor is being installed, it is connected to the radar sensor cable on the console and the extra connector on the planter harness is not used. If the magnetic distance sensor is being installed, it is connected to the planter harness and the sensor cable on the console is not used. Neither the radar distance sensor or the magnetic distance sensor is used with the KPM I console. Bundle and tie any unused harness connectors to the harness so they will not be damaged. **DO NOT** connect distance sensor or seed tubes at this time.

## MODEL 3120 3 POINT MOUNTED PLANTER (Vertical Folding)

(8 Row Shown)

(PLTR118a)

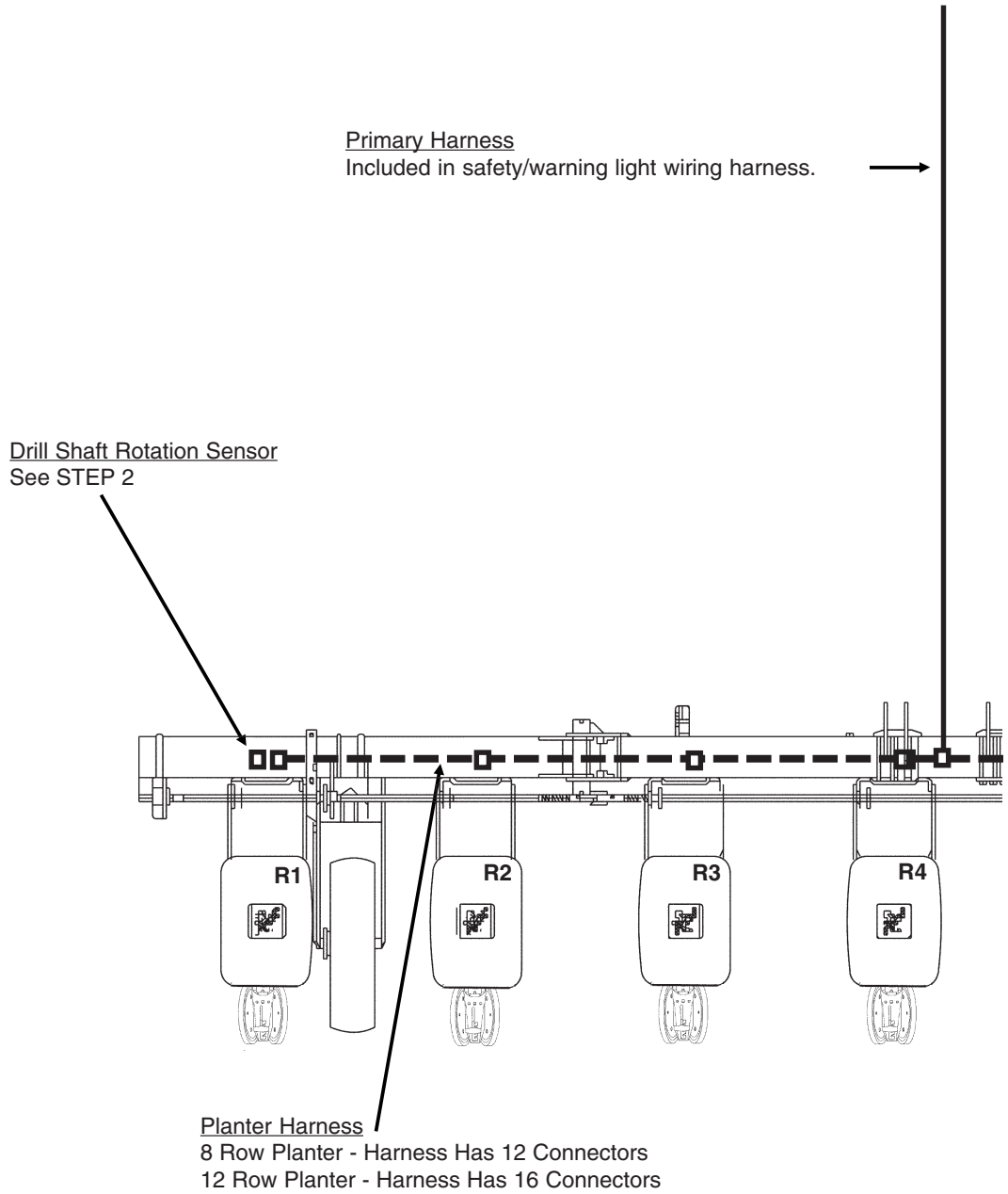

**NOTE:** If the radar distance sensor is being installed, it is connected to the radar sensor cable on the console and the extra connector on the planter harness is not used. If the magnetic distance sensor is being installed, it is connected to the planter harness and the sensor cable on the console is not used. Neither the radar distance sensor or the magnetic distance sensor is used with the KPM I console. Bundle and tie any unused harness connectors to the harness so they will not be damaged. **DO NOT** connect distance sensor or seed tubes at this time.

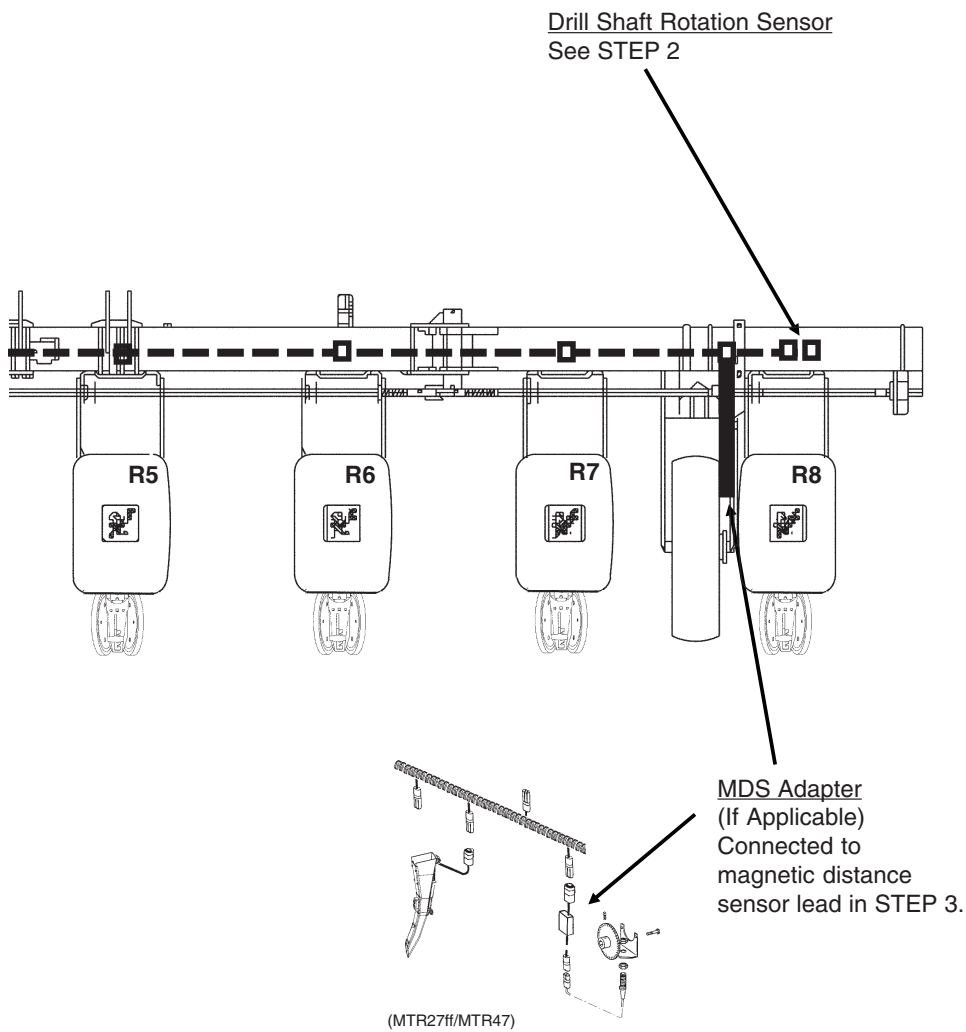

## MODEL 3140 3 POINT MOUNTED PLANTER (Stack Folding)

(8 Row Shown)

(PLTR119a)

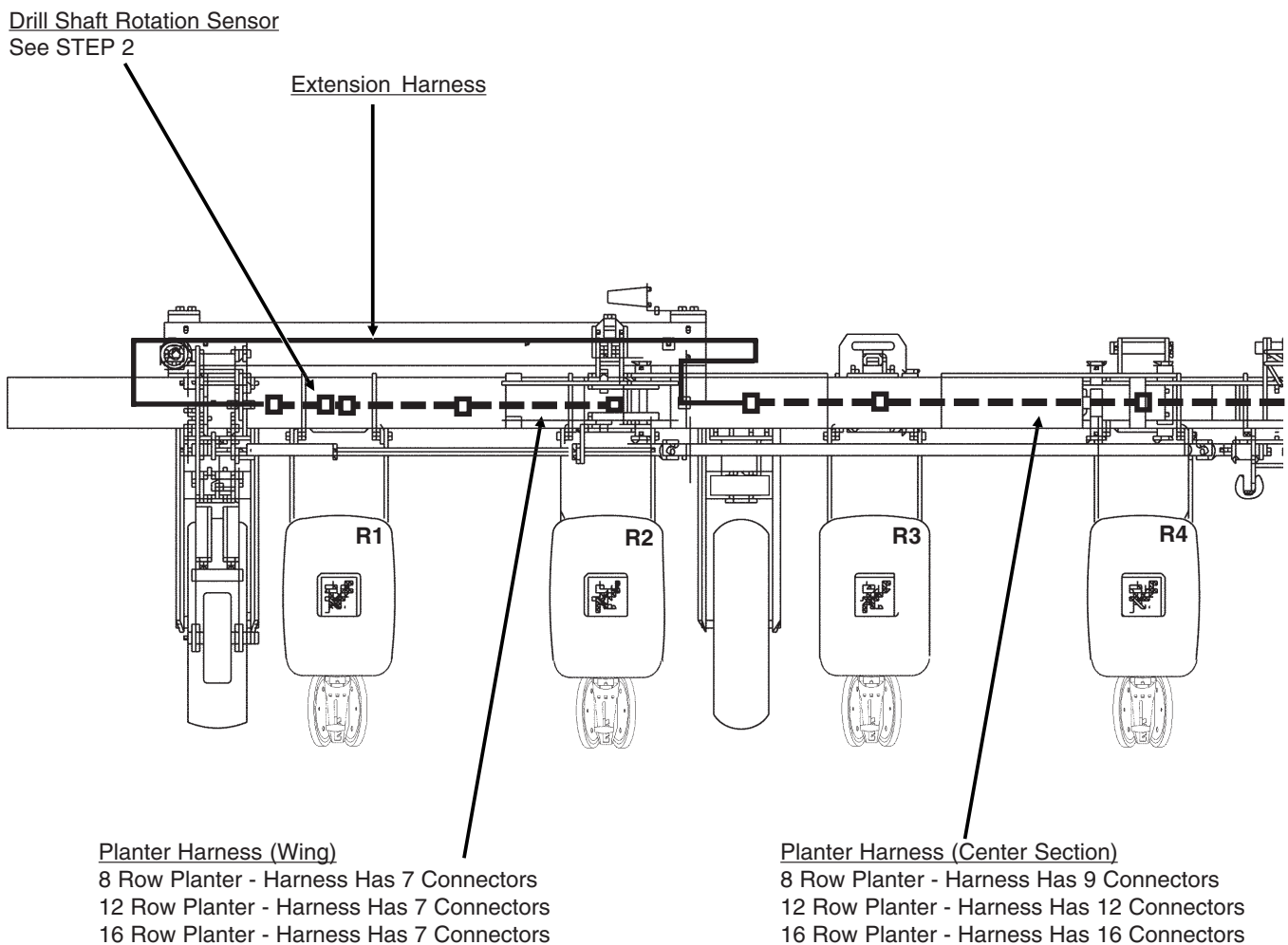

**NOTE:** If the radar distance sensor is being installed, it is connected to the radar sensor cable on the console and the extra connector on the planter harness is not used. If the magnetic distance sensor is being installed, it is connected to the planter harness and the sensor cable on the console is not used. Neither the radar distance sensor or the magnetic distance sensor is used with the KPM I console. Bundle and tie any unused harness connectors to the harness so they will not be damaged. **DO NOT** connect distance sensor or seed tubes at this time.

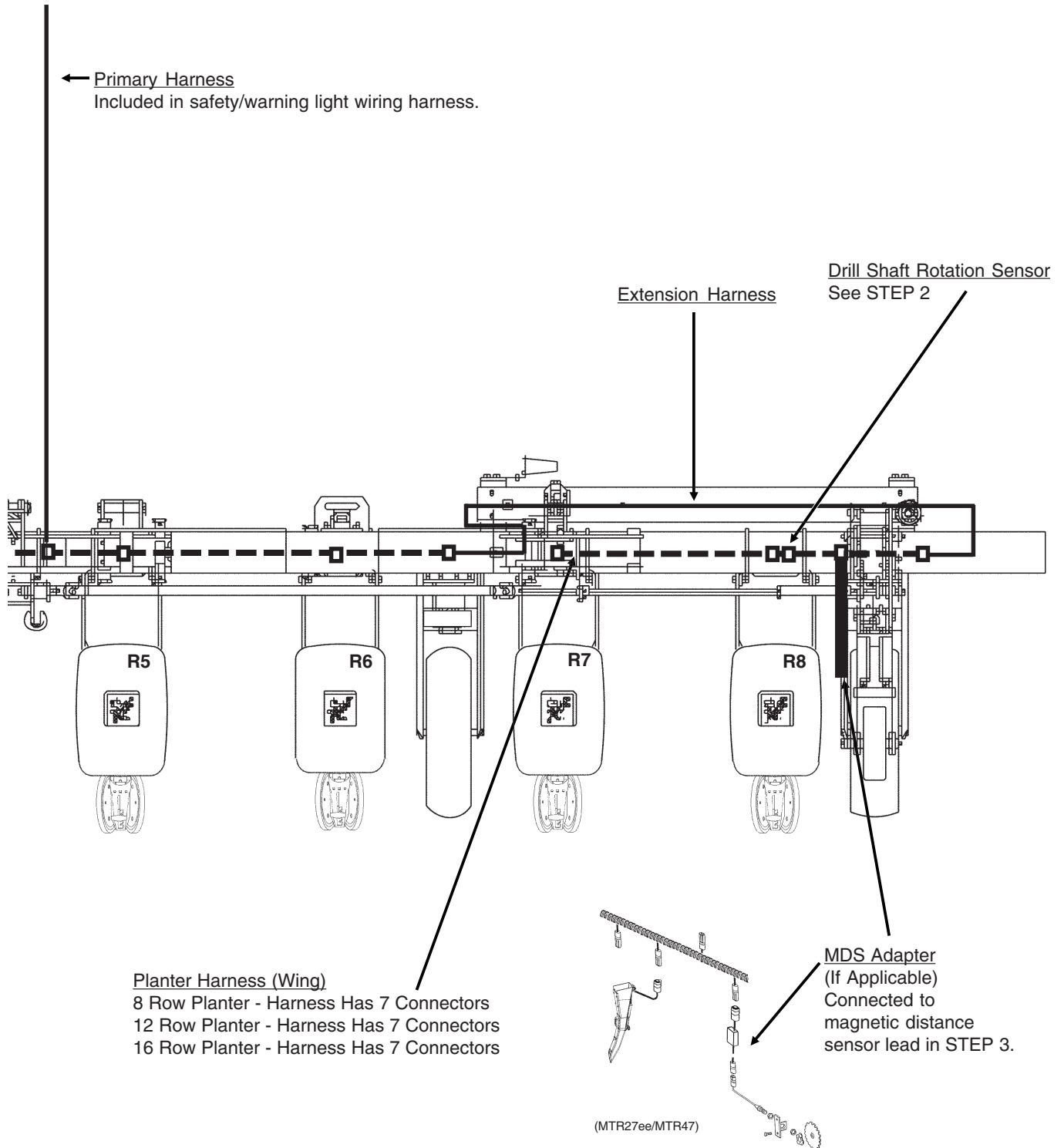

## MODEL 3200 FLEX ECONO-FOLD® PLANTER

(12 Row Shown)

(PLTR148b/PLTR148c)

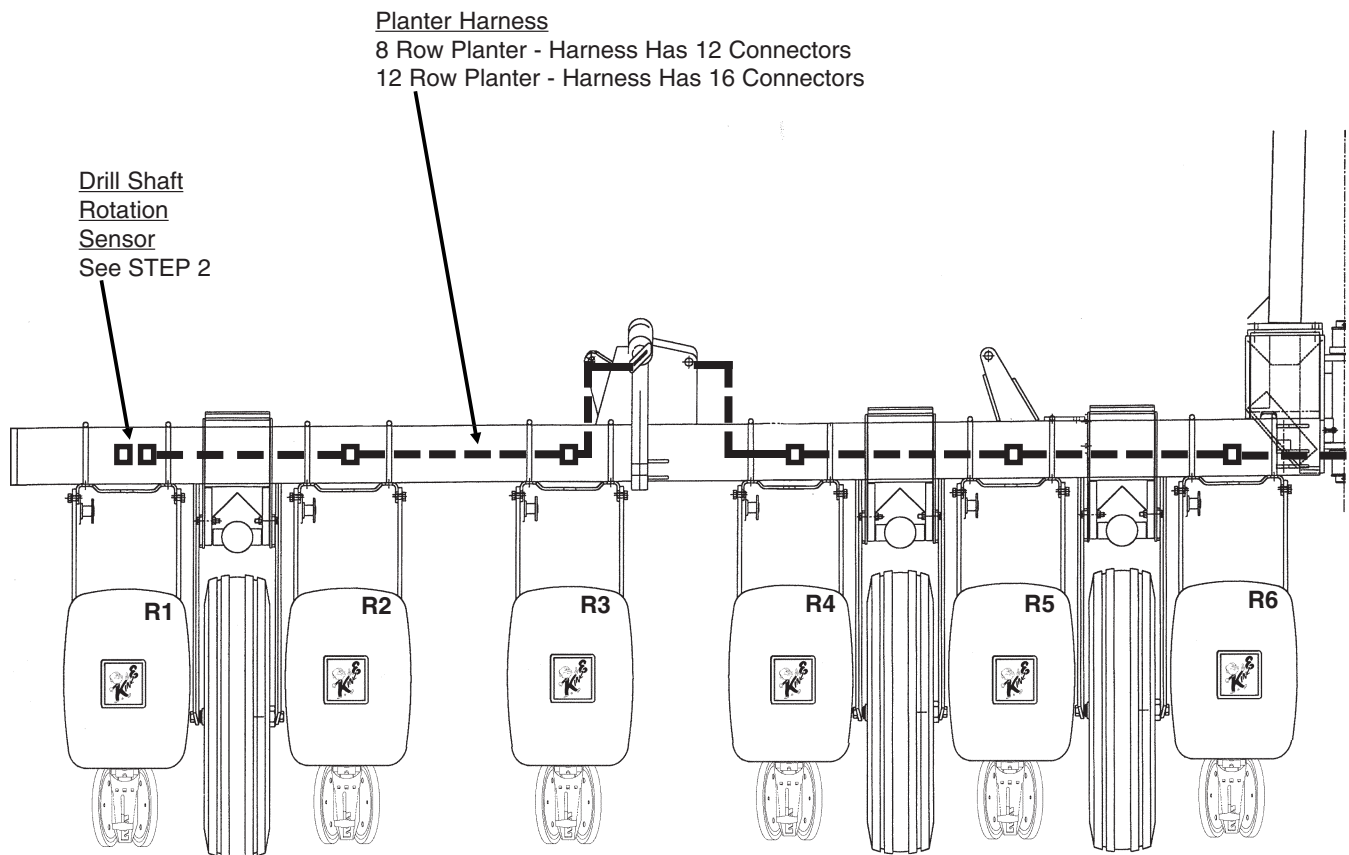

**NOTE:** If the radar distance sensor is being installed, it is connected to the radar sensor cable on the console and the extra connector on the planter harness is not used. If the magnetic distance sensor is being installed, it is connected to the planter harness and the sensor cable on the console is not used. Neither the radar distance sensor or the magnetic distance sensor is used with the KPM I console. Bundle and tie any unused harness connectors to the harness so they will not be damaged. **DO NOT** connect distance sensor or seed tubes at this time.

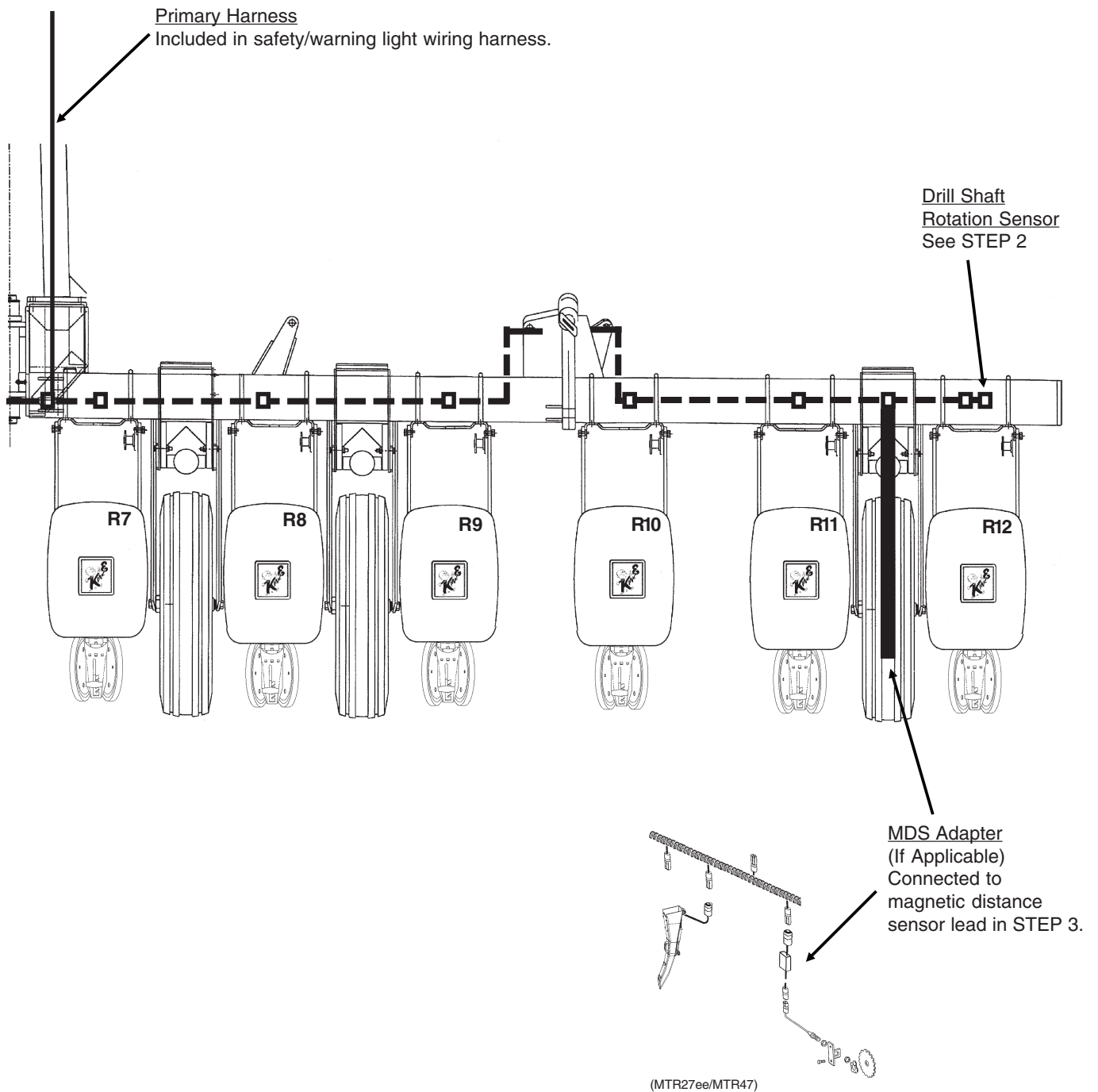

## MODEL 3400 TWIN-LINE® PLANTER WITH INTERPLANT® PACKAGE

### (12 Row With 11 Push Row Units Shown)

(PLTR147/MTR27ee/MTR47)

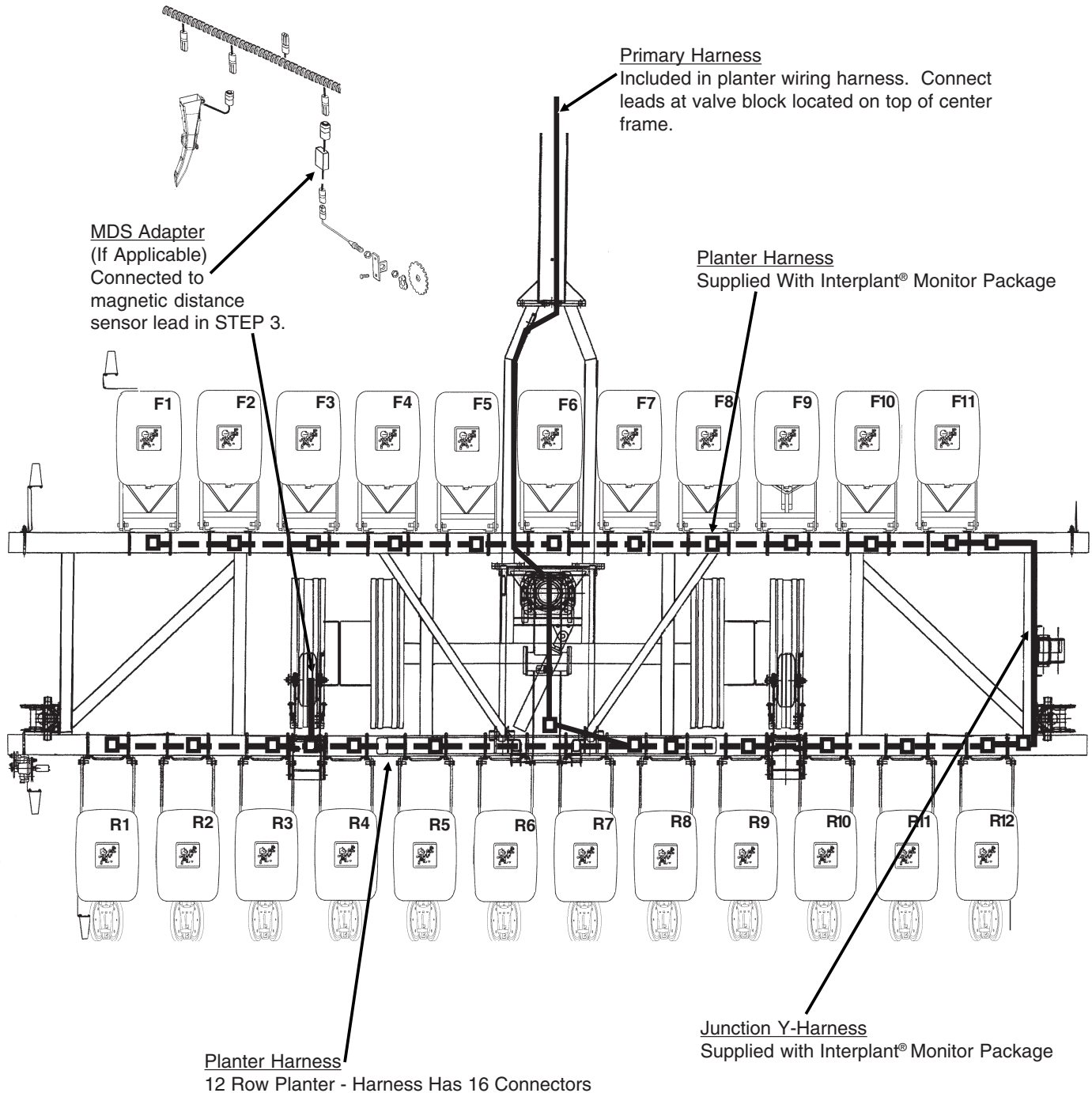

**NOTE:** If the radar distance sensor is being installed, it is connected to the radar sensor cable on the console and the extra connector on the planter harness is not used. If the magnetic distance sensor is being installed, it is connected to the planter harness and the sensor cable on the console is not used. Neither the radar distance sensor or the magnetic distance sensor is used with the KPM I console. Bundle and tie any unused harness connectors to the harness so they will not be damaged. **DO NOT** connect distance sensor or seed tubes at this time.

## MODEL 3500 TWIN-LINE® PLANTER WITH INTERPLANT® PACKAGE

(8 Row With 7 Push Row Units Shown)

(PLTR121r)

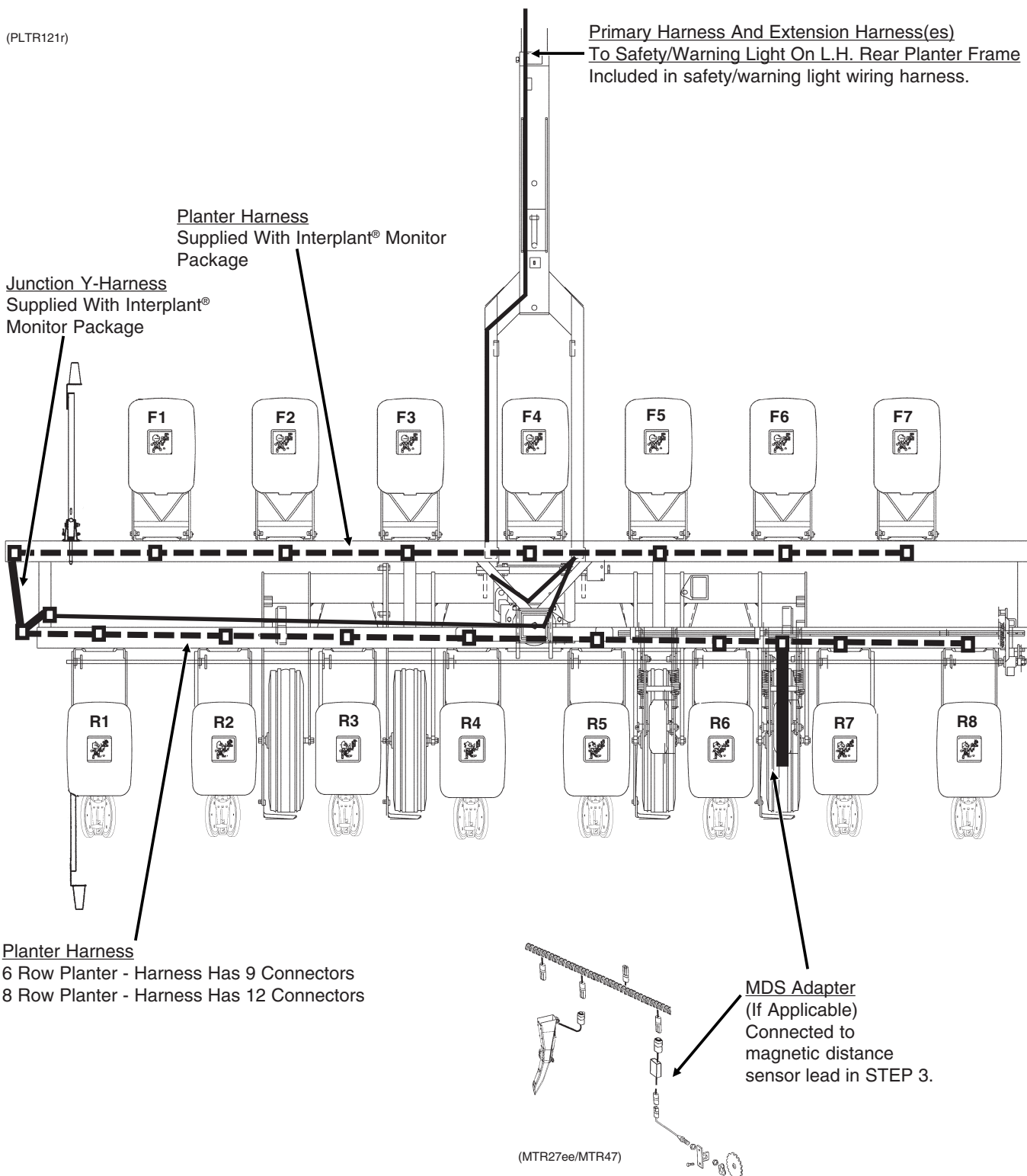

Planter Harness  
 6 Row Planter - Harness Has 9 Connectors  
 8 Row Planter - Harness Has 12 Connectors

**NOTE:** If the radar distance sensor is being installed, it is connected to the radar sensor cable on the console and the extra connector on the planter harness is not used. If the magnetic distance sensor is being installed, it is connected to the planter harness and the sensor cable on the console is not used. Neither the radar distance sensor or the magnetic distance sensor is used with the KPM I console. Bundle and tie any unused harness connectors to the harness so they will not be damaged. **DO NOT** connect distance sensor or seed tubes at this time.

## MODEL 3600 TWIN-LINE® PLANTER WITH INTERPLANT® PACKAGE

(Model 3600 12 Row With 11 Push Row Units Shown)

(PLTR132h/PLTR132d)

Drill Shaft Rotation Sensor  
See STEP 2

**NOTE: On 8 and 12 row sizes equipped with Interplant® Package, the drill shaft rotation sensors will have to be installed on the 2nd row in on each side of the planter to avoid interference with the Interplant® Package drive.**

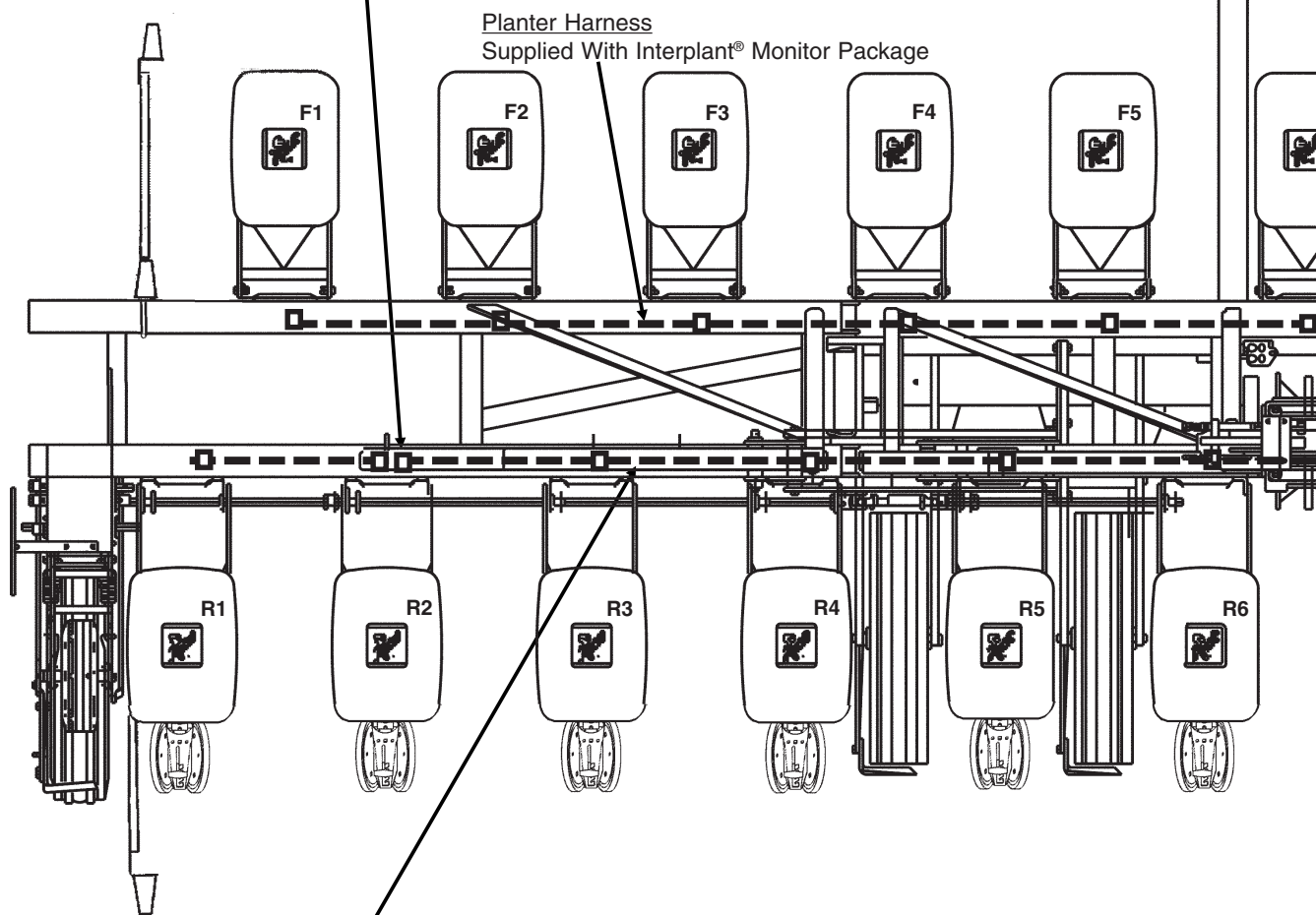

Planter Harness  
Supplied With Interplant® Monitor Package

Planter Harness  
8 Row Planter - Harness Has 12 Connectors  
12 Row Planter - Harness Has 16 Connectors  
16 Row Planter - Harness Has 20 Connectors

**NOTE: If the radar distance sensor is being installed, it is connected to the radar sensor cable on the console and the extra connector on the planter harness is not used. If the magnetic distance sensor is being installed, it is connected to the planter harness and the sensor cable on the console is not used. Neither the radar distance sensor or the magnetic distance sensor is used with the KPM I console. Bundle and tie any unused harness connectors to the harness so they will not be damaged. DO NOT connect distance sensor or seed tubes at this time.**

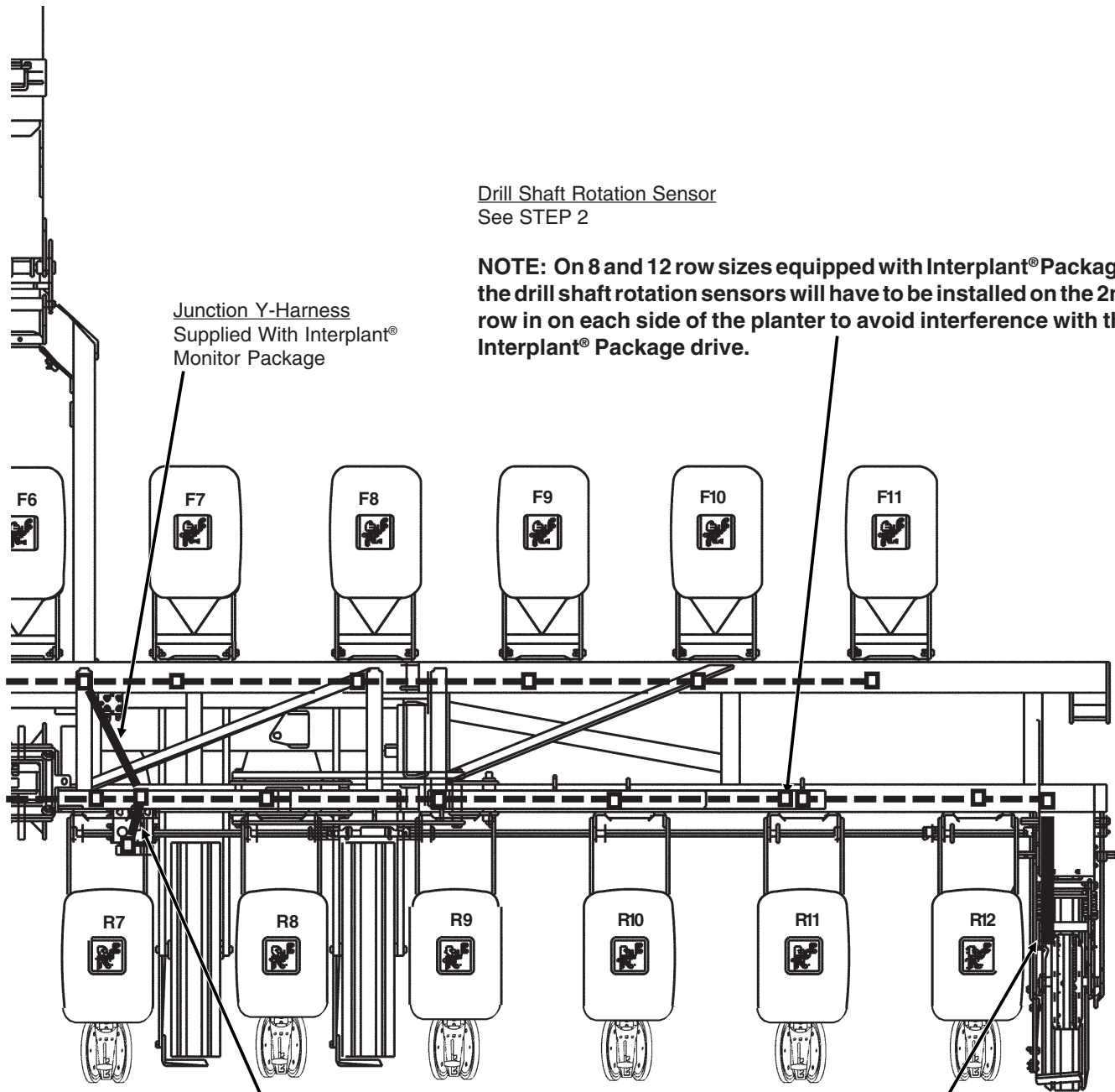

Drill Shaft Rotation Sensor  
See STEP 2

**NOTE:** On 8 and 12 row sizes equipped with Interplant® Package, the drill shaft rotation sensors will have to be installed on the 2nd row in on each side of the planter to avoid interference with the Interplant® Package drive.

Junction Y-Harness  
Supplied With Interplant®  
Monitor Package

Primary Harness  
Included in the planter wiring harness. Connect to leads from hydraulic control harness located on rear center frame.

MDS Adapter  
(If Applicable)  
Connected to magnetic distance sensor lead in STEP 3.

(MTR27ee/MTR47)

## MODEL 3650 TWIN-LINE® PLANTERS WITH INTERPLANT® PACKAGE

(Model 3650 Bulk Fill 12 Row With 11 Push Row Units Shown)

(TWL254)

Drill Shaft Rotation Sensor  
See STEP 2

Planter Harness  
Supplied With Interplant® Stack-Mode Monitor Package

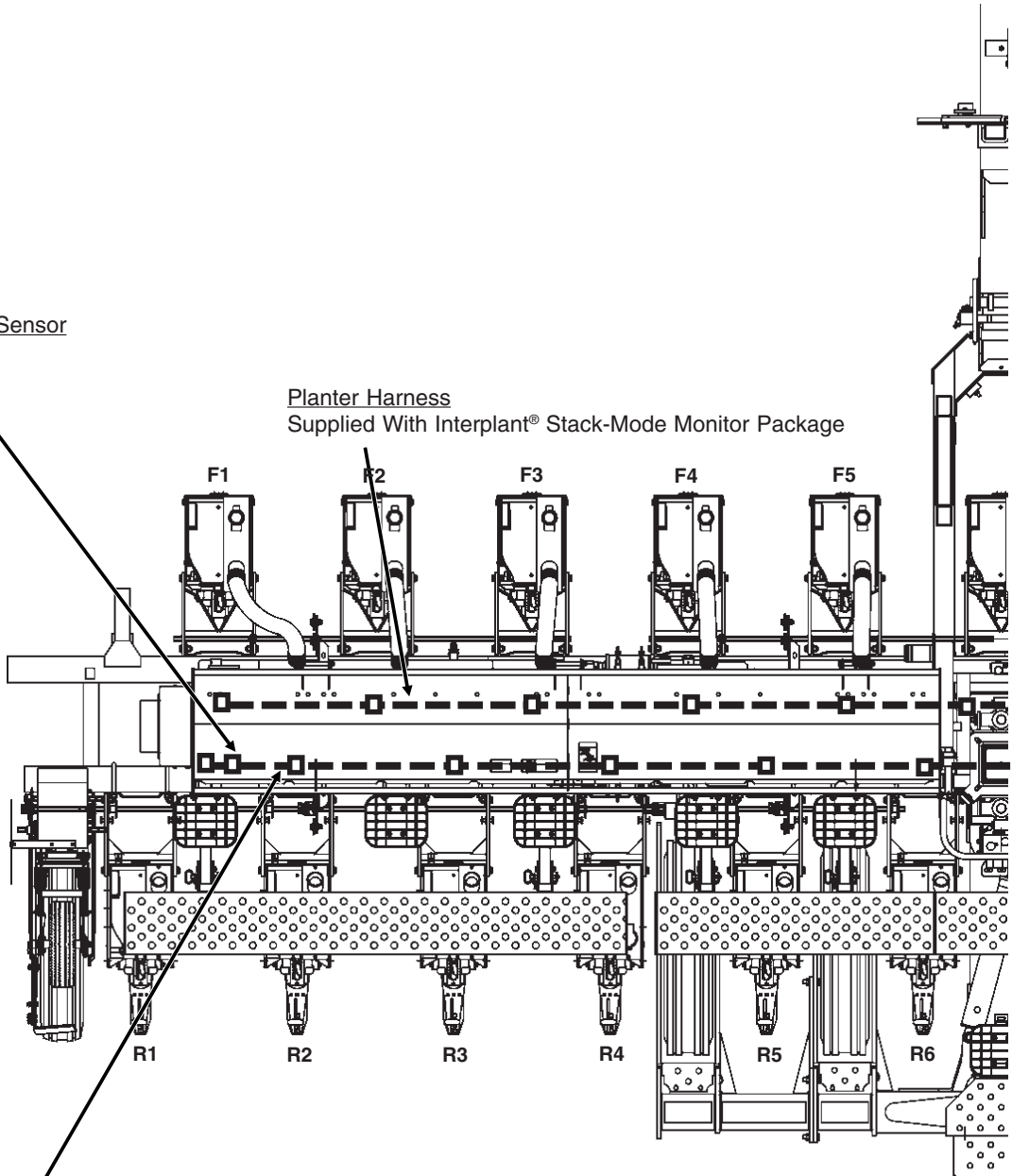

Planter Harness  
12 Row Planter - Harness Has 16 Connectors  
16 Row Planter - Harness Has 20 Connectors

**NOTE:** If the radar distance sensor is being installed, it is connected to the radar sensor cable on the console and the extra connector on the planter harness is not used. If the magnetic distance sensor is being installed, it is connected to the planter harness and the sensor cable on the console is not used. Bundle and tie any unused harness connectors to the harness so they will not be damaged. **DO NOT** connect distance sensor or seed tubes at this time.

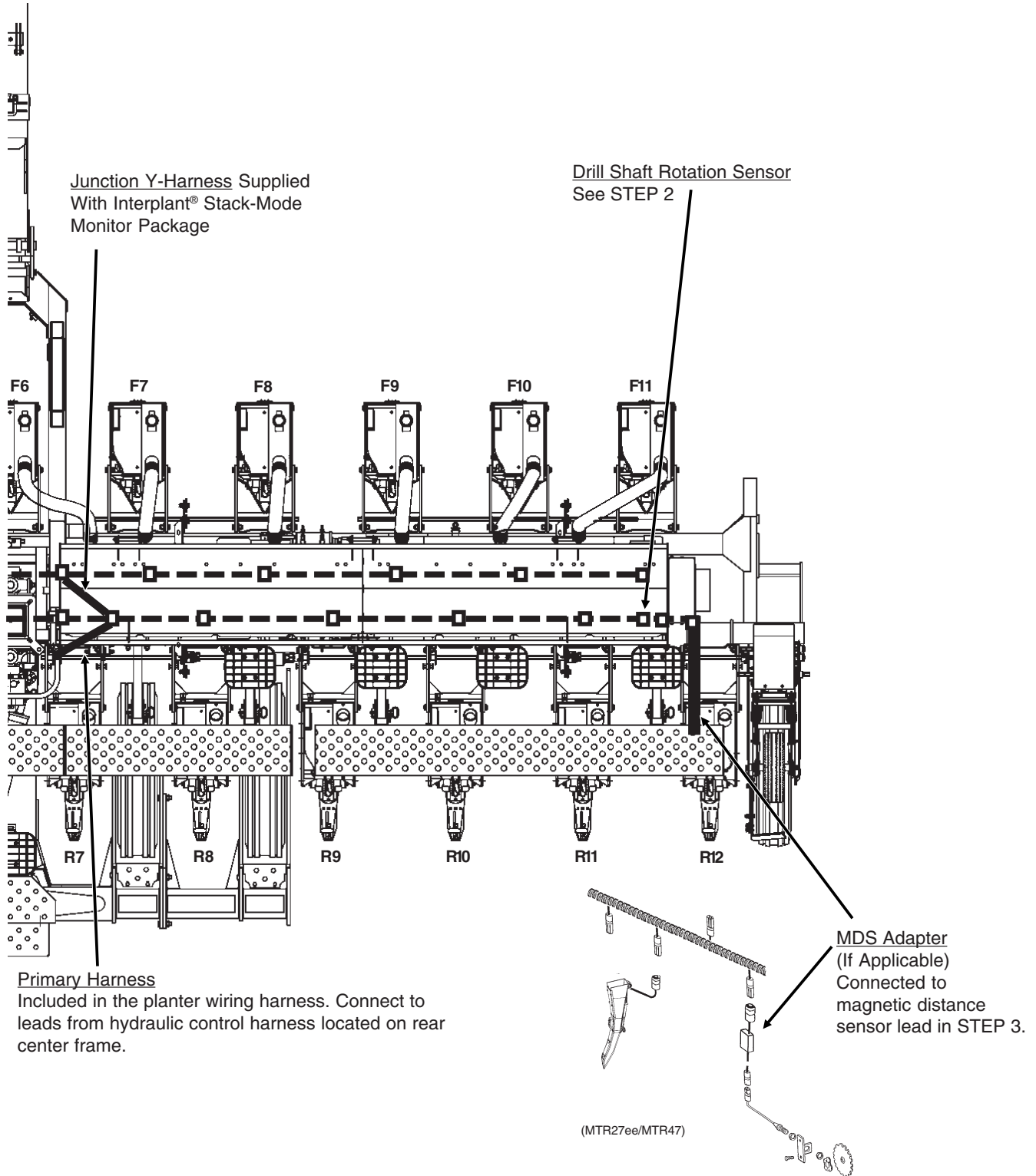

## MODEL 3700 FRONT FOLDING PLANTER

### 24 Row 30" Shown

(FF94)

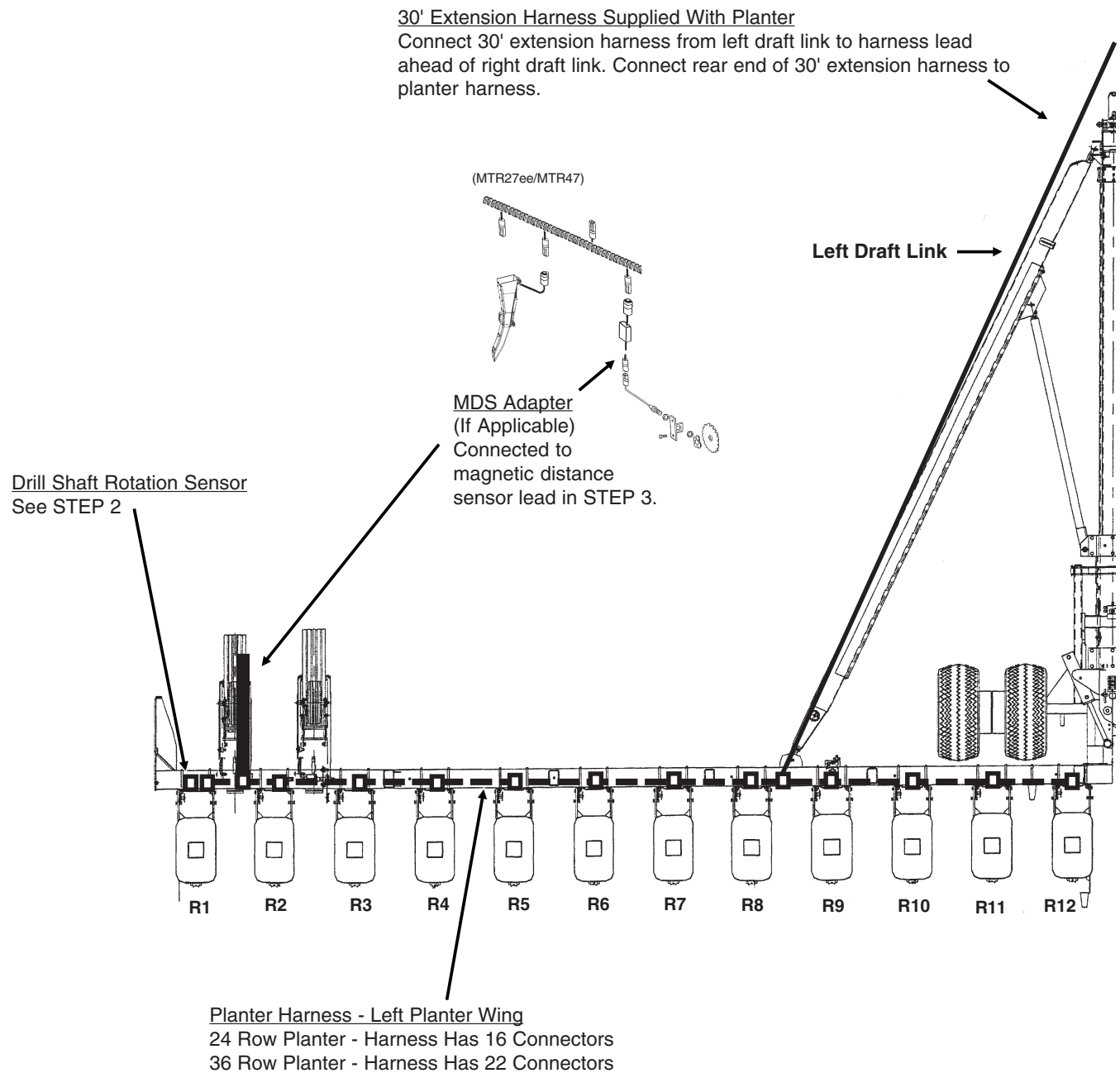

**NOTE:** If the radar distance sensor is being installed, it is connected to the radar sensor cable on the console and the extra connector on the planter harness is not used. If the magnetic distance sensor is being installed, it is connected to the planter harness and the sensor cable on the console is not used. Bundle and tie any unused harness connectors to the harness so they will not be damaged. **DO NOT** connect distance sensor or seed tubes at this time.

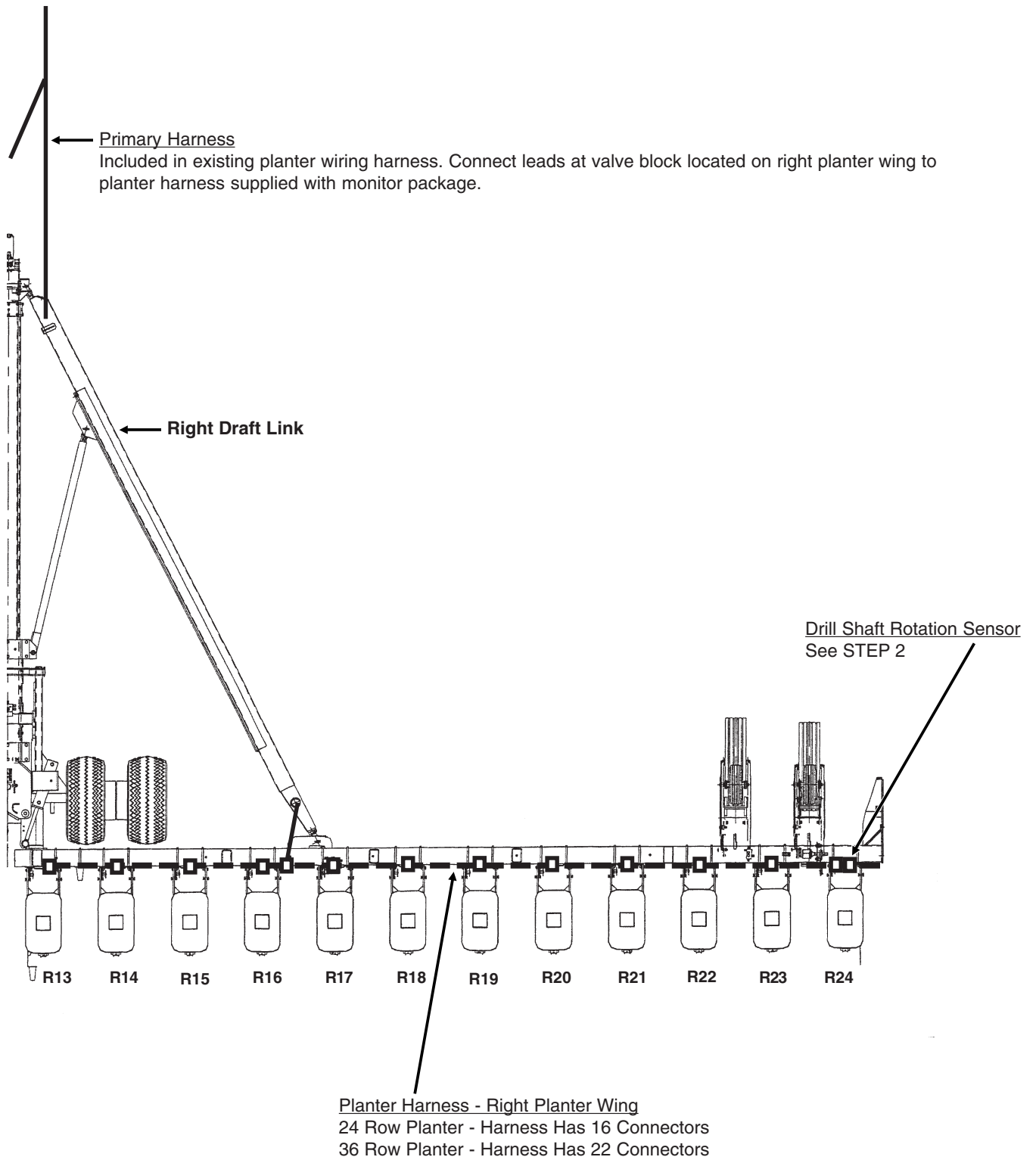

## MODEL 3800 FORWARD FOLDING PLANTER

### 32 Row 30" Shown

(FDW4a)

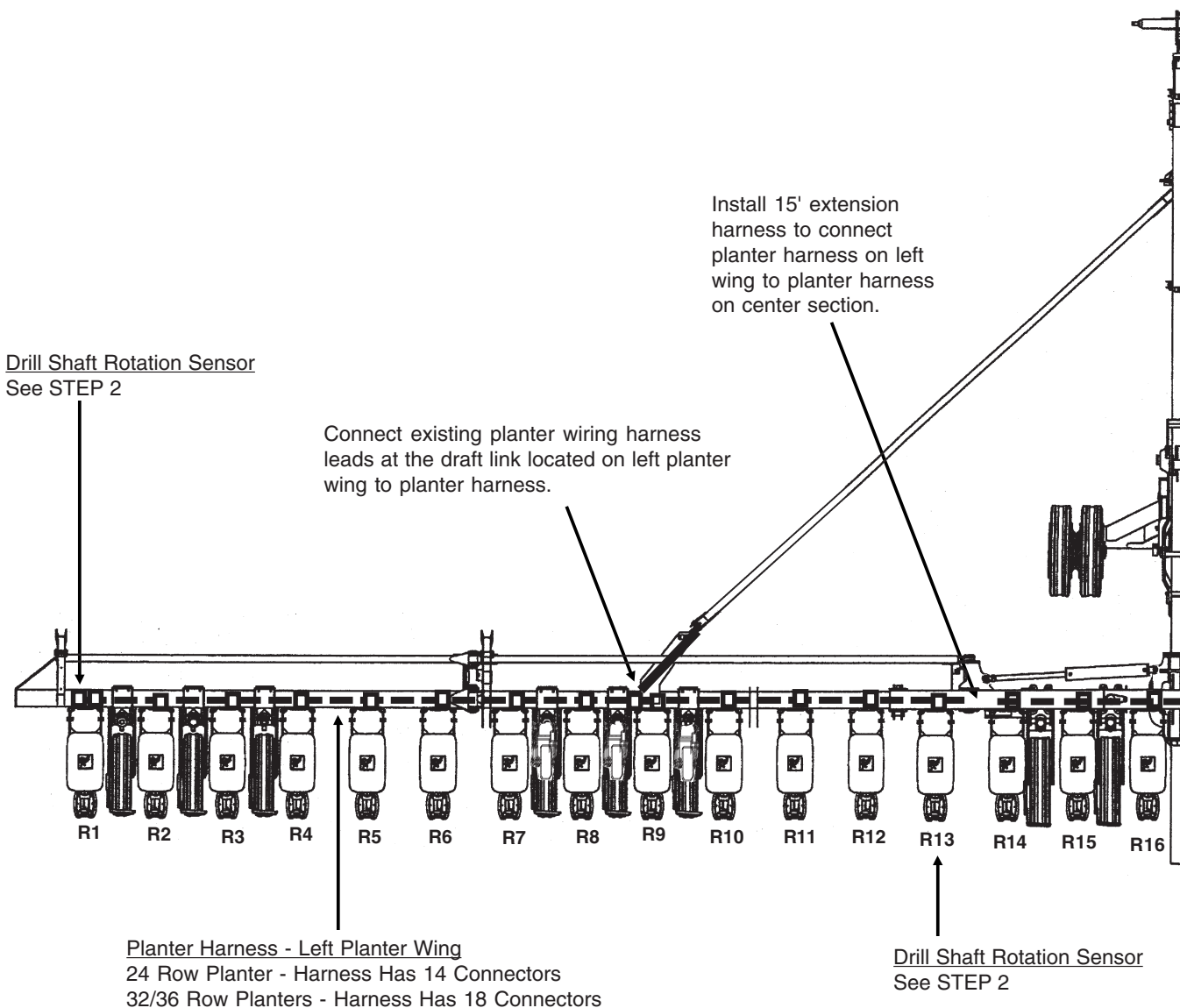

**NOTE:** If the radar distance sensor is being installed, it is connected to the radar sensor cable on the console and the extra connector on the planter harness is not used. If the magnetic distance sensor is being installed, it is connected to the planter harness and the sensor cable on the console is not used. Bundle and tie any unused harness connectors to the harness so they will not be damaged. **DO NOT** connect distance sensor or seed tubes at this time.

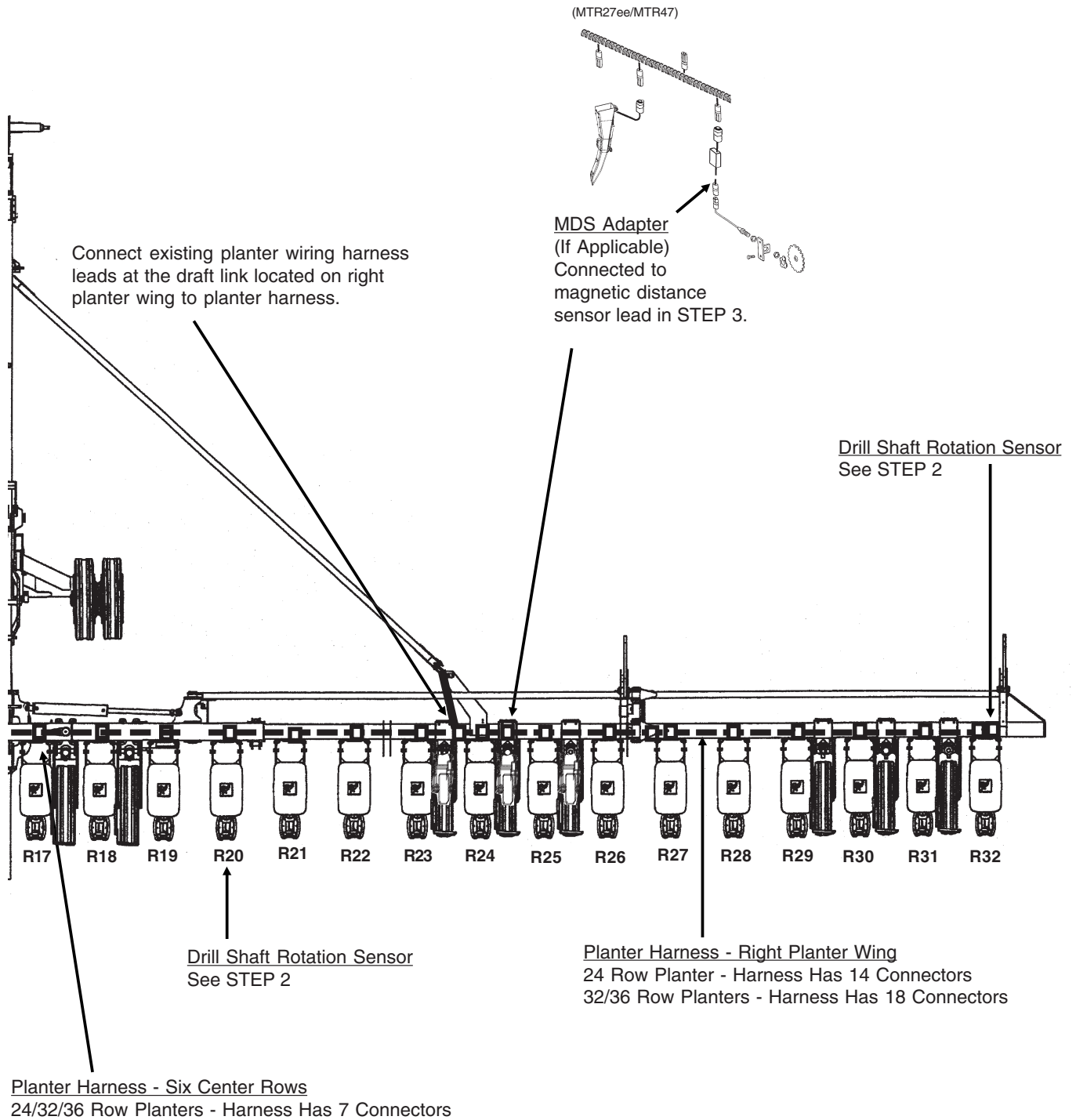

## Introduction

**NOTE:** The console must be connected to a 12 volt power source.

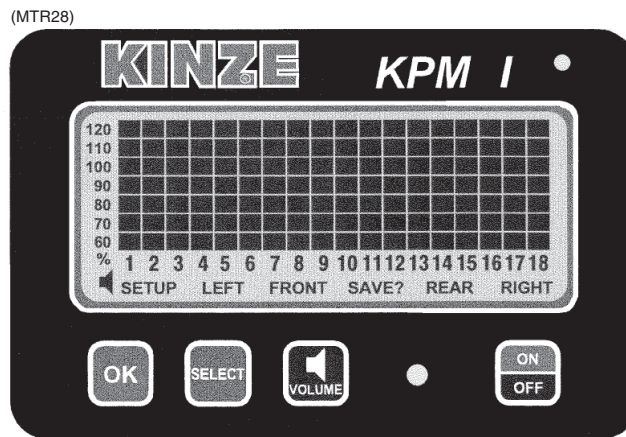

The KPM I electronic seed monitor system consists of a console, which is mounted on the tractor; seed tubes with computerized sensors, one of which is installed in each planter row unit; a primary harness\*, which connects the console to the planter harness; and a planter harness (junction Y-harness and/or harness extension where applicable), to which the individual seed tube sensors connect.

\* **NOTE:** The primary harness, on all 3000 Series Planters, is hard-wired into the safety/warning light harness or control console wiring harness included as standard equipment with the planter.

Seed flow for up to 36 rows, in two 18 row sections (left/right or rear/front), may be monitored with one monitor. For less complicated applications (18 rows or less), all rows may be programmed in one section and the other section left disabled.

The monitor system is powered by the tractor battery (requires 12 volts DC). The console receives information from each of the sensors and translates this information.

The single backlit Liquid Crystal Display (LCD) shows the active section, the number of monitored rows per section, the relative seed rate for each row (using a bar graph display) and scrolls various alarm and warning messages when an alarm condition exists. A continuous audible alarm will sound upon system malfunction or underflow conditions for any monitored row. Alarms must be acknowledged by the user. Various warnings may sound the alarm or flash one or more icons.

The monitor will power down if no activity is detected within one hour. No activity means there has been no new seed flow and no operator push key input. (If applicable)

## MONITOR KEY FUNCTIONS

Each key press is acknowledged by the monitor with a short beep.

### OK

- Ends and saves the new setup during installation.
- Acknowledges and silences alarms in the operation mode.

### SELECT

- Selects the application mode (rear/front or left/right) at the beginning of installation setup.
- Selects the active section(s) (rear, rear/front, left, right or left/right) in the operation mode.
- Has no affect on a system configured to monitor only one section.

### VOLUME

- Pressing the key will turn the audible alarm on.
- Holding the key for periods of 2 seconds increases the volume until it reaches the maximum, at which time it rolls over to the minimum level.

### ON/OFF

- Powers the unit on and off.

- STEP 1** All the seed tubes w/sensors must be disconnected from the harness and the monitor must be off.
- STEP 2** Press the ON key. The monitor automatically enters the setup mode. If the monitor was accidentally powered on with no sensors attached, the user can turn the monitor off at this point and the previous configuration is not lost.
- STEP 3** Press the SELECT key. Each time you press the SELECT key the mode will toggle between rear/front and left/right. The selected display will be solid and the configuration not currently selected will be flashing. By default the monitor starts in rear/front mode.

01229910

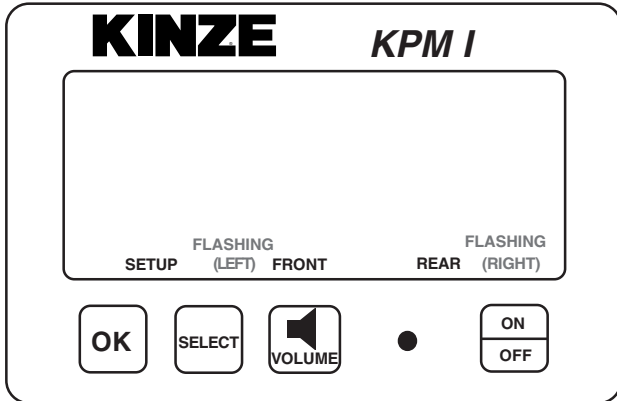

01229911

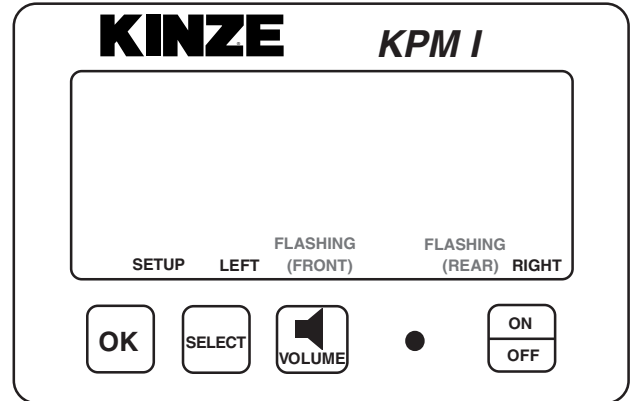

**NOTE:** Model 3700 (24/36 row) planters will use the left/right configuration. Models 3000, 3110, 3120, 3140, 3200, 3400, 3500, 3600/3650 and 3700 (16 row) planters will use the rear configuration only. On Model 3000, 3400, 3500 and 3600/3650 planters equipped with Interplant® Packages, the rear/front configuration will be used. When all rows can be viewed on a single display (rear), pressing the select key has no function.

- STEP 4** Press and hold the OK key to confirm the selection and continue holding until the row numbers appear on the top display. During confirmation, the display will alternate between “NEW” and “SYS” to alert the user that the previous configuration will be lost. With the rear/front mode selected, the monitor automatically starts with the rear section. The REAR icon shows solid and the FRONT icon starts to flash. With the left/right mode selected, the monitor automatically starts with the left section. The LEFT icon shows solid and the RIGHT icon starts to flash.

01229912

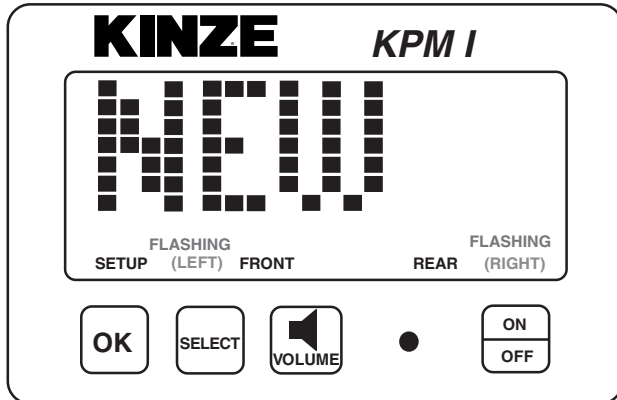

01229912a

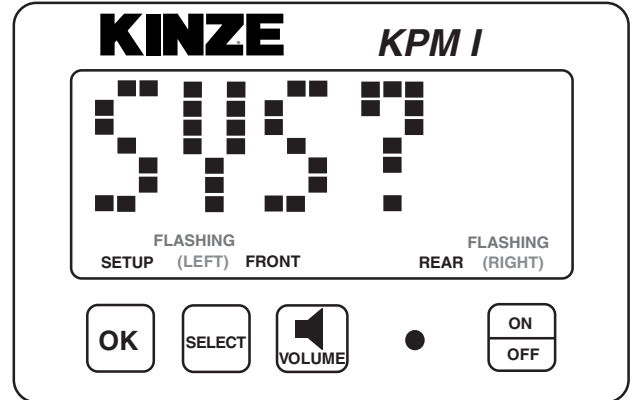

**STEP 5** Plug each seed tube w/sensor into the harness in a predetermined order. Row 1 first, row 2 second and so on up to 18 rows. When a sensor is plugged in, the corresponding row number on the LCD display will stay solid, the monitor will chirp twice and the LED (Light Emitting Diode) on the seed tube sensor will turn on for approximately 30 seconds to show connection is made. NOTE: Unless there is a faulty sensor, the installer should just have to connect the sensors in the proper order without checking the monitor is acknowledging each sensor.

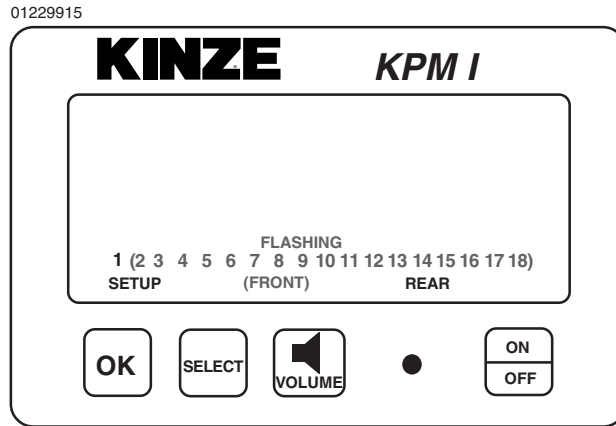
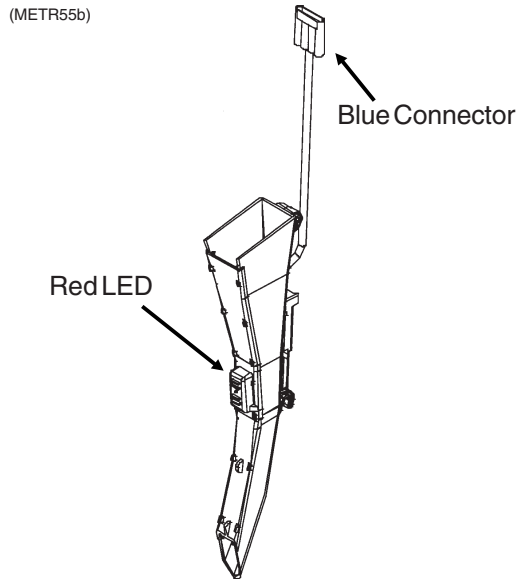

**STEP 6** When all the seed tubes w/sensors for the current section are installed, check to be sure the monitor displays solid numbers for the number of sensors connected.

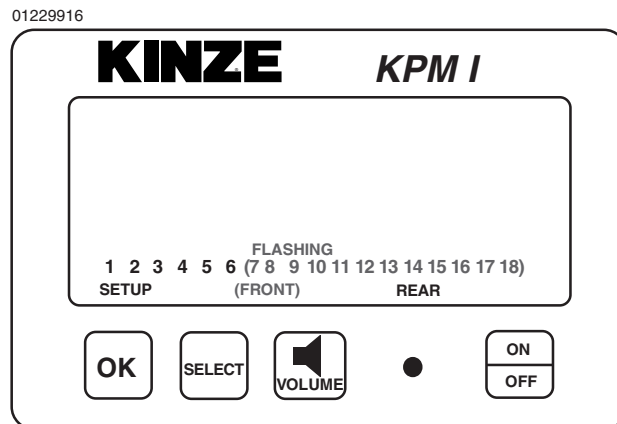

**STEP 7** If this condition is satisfied, press and hold the OK key to save the setup for the current section. The SAVE? icon will show followed by continuous short beeps indicating the monitor is preparing to save. The installer has 5 seconds to decide if he wants to save the current configuration. During this time the short beeps will sound. To complete the save, hold the OK key pressed until the word “DONE” shows on the screen followed by a long beep and the SAVE? icon turns off. When the OK key is released the monitor will continue with the second section installation.

01229917

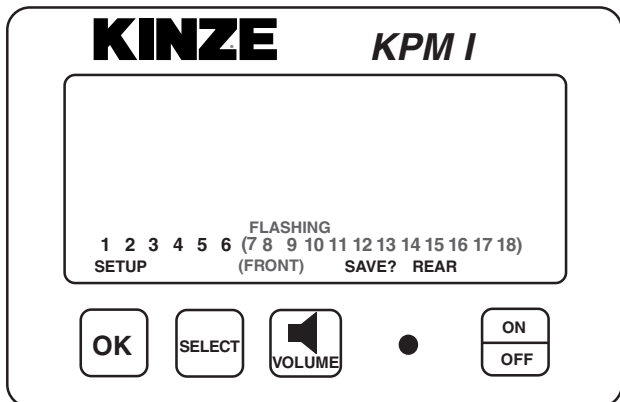

01229918

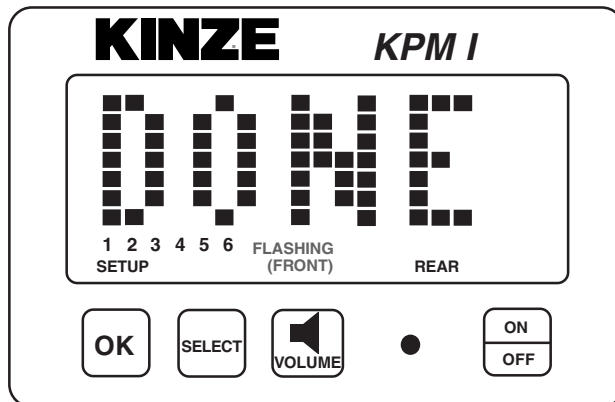

**STEP 8** Follow STEPS 5 through 7 to install the second section (FRONT or RIGHT). If no seed tubes are installed on the second section, press and hold the OK key until the word “DONE” shows on the screen followed by a long beep and the SAVE? icon turns off.

01229919

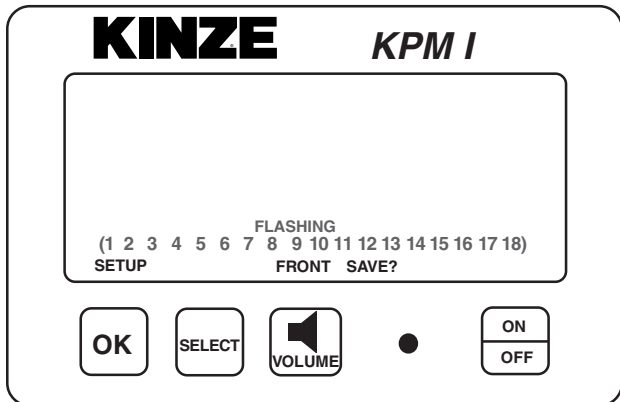

01229920

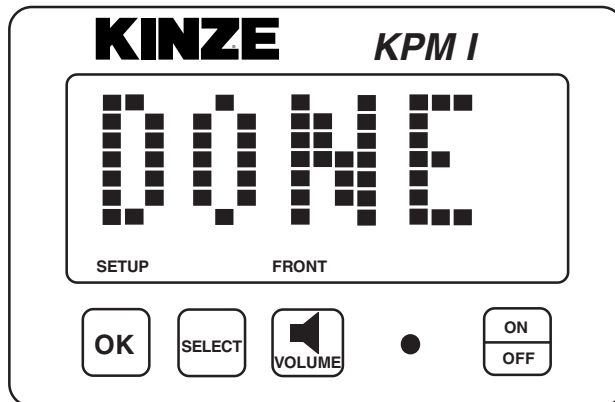

**NOTE:** Individual seed tubes may be unplugged for special situations. An alarm will sound which can be silenced by touching the OK key. The monitor will recognize each seed tube when reconnected.

# KPM II STACK-MODE - PROGRAMMING/CONNECTING IS628 SMM CONSOLE, SHAFT ROTATION SENSORS, SEED TUBES AND/OR RADAR/MAGNETIC DISTANCE SENSORS

## Introduction

(MTR41d)

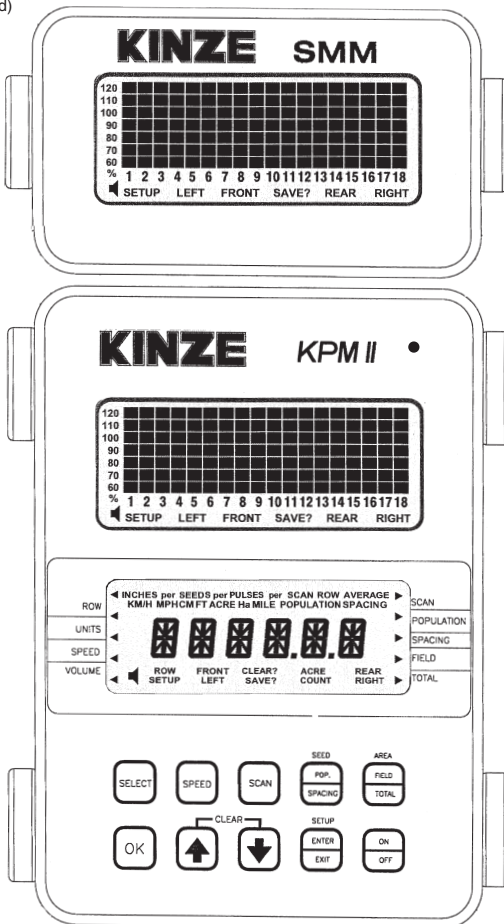

**NOTE: SMM console may not be applicable to all models.**

The KPM II Stack-Mode electronic seed monitor system consists of (a) a KPM II Stack-Mode console, which is mounted on the tractor; (b) seed tubes with sensors, one of which is installed in each planter row unit; (c) a magnetic distance sensor, which is installed on the planter, or a radar distance sensor, which is installed on the tractor; (d) shaft rotation sensors, which are installed on the planter drill shafts; and (e) a planter harness (junction Y-harness and/or extension harness where applicable), to which the individual seed tube sensors connect. The primary harness, which connects the monitor console to the planter harness, is hard-wired into the safety/warning light harness or control console harness included as standard equipment with the planter.

The software design of the KPM II Stack-Mode console allows the use of an add-on SMM console for simultaneous viewing of the seed flow bar graphs for standard and/or Interplant® System rows (up to 36 rows in two sections). A total of 72 rows may be displayed in multiple sections (rear/front, left/right or four sections). The SMM console must be used to allow utilization of the four section feature.

The SMM console is included with the KPM II Stack-Mode Electronic Seed Monitor Package for 24 and 36 row Model 3700 and all Model 3800 planters. It is available as a separate package for use when 3400, 3600 or 3650 planters are equipped with Interplant® Package rows.

The monitor system is powered by the tractor battery (requires 12 volts DC). The console receives information from each of the sensors and translates this information.

The KPM II Stack-Mode console has two backlit Liquid Crystal Displays (LCD). The upper display shows the active section, the number of monitored rows per section, the relative seed rate for each row (using a bar graph display) and scrolls various alarm and warning messages when an alarm condition exists. A continuous audible alarm will sound upon system malfunction or underflow conditions for any monitored row. Alarms must be acknowledged by the user. Various warnings may sound the alarm or flash one or more icons. The lower display is used to display alphanumeric data such as row spacing, units (Metric or English), speed, volume, seed population, seed spacing, field area, total area and distance sensor pulses per mile/kilometer.

The SMM console has one backlit Liquid Crystal Display (LCD) which functions the same as the upper display on the KPM II Stack-Mode console except it does not scroll alarm and warning messages. The SMM console must be programmed into the system before printed text will display on the LCD.

The monitor system will power down if no activity is detected within one hour. No activity means there has been no new seed flow and no operator push key input.

# KPM II STACK-MODE - PROGRAMMING/CONNECTING IS628 SMM CONSOLE, SHAFT ROTATION SENSORS, SEED TUBES AND/OR RADAR/MAGNETIC DISTANCE SENSORS

---

## MONITOR KEY FUNCTIONS

Push keys allow the user to select or change the operating mode, the active displays or the current configuration. Depending on the operating mode or the current display selected, some keys are valid while some are not. Each key press, if valid, is acknowledged by a short beep and an action is taken. If the key press has no action associated, the key press is considered invalid, and the user will not get any feedback.

### SELECT

- Selects the application mode (rear/front, left/right or four sections up to a maximum of 72 rows) at the beginning of installation in the setup mode.
- Selects the active section(s) (rear, rear/front, left, right or left/right) in the operation mode.
- Has no affect on a system configured to monitor only one section.
- While programming the monitor, the key will select the digit to change.

### SPEED

- Immediately displays the current ground speed.

### SCAN

- If the current average population or average spacing is displayed, this key sequentially displays the seed population/spacing on each row.
- If the display shows functions other than average seed population or spacing, pressing SCAN will sequentially display speed, average seed population and average seed spacing.
- Pressing a second time freezes the display on the current row.
- Pressing a third time restarts the sequential display.

### SEED POPULATION/SEED SPACING

- Immediately displays the average seed POPULATION and the average seed SPACING of all active rows.
- Each press alternates between seed spacing and seed population.

### AREA FIELD/AREA TOTAL

- Immediately displays the field or total area planted since the field/total area was last cleared.
- Each press alternates between field area and total area.

### OK

- Ends and saves the new setup during installation.
- Acknowledges and silences alarms in the operation mode.

### UP ARROW AND DOWN ARROW

- Scrolls sequentially through the display options on the lower LCD display.
- Freezes on the current row in the scan mode.
- Scrolls sequentially through the rows when the population scan is frozen.
- Used to enter programmable values in the programming mode.
- The UP and DOWN Arrow keys can be pressed at the same time to start the CLEAR function.

### SETUP ENTER/SETUP EXIT

- Enters and exits the programming mode.

### ON/OFF

- Powers the unit on and off.

# KPM II STACK-MODE - PROGRAMMING/CONNECTING IS628 SMM CONSOLE, SHAFT ROTATION SENSORS, SEED TUBES AND/OR RADAR/MAGNETIC DISTANCE SENSORS

## PROGRAMMING/CONNECTING SMM CONSOLE, SHAFT ROTATION SENSORS, SEED TUBES AND/OR RADAR/MAGNETIC DISTANCE SENSORS

**STEP 1** All sensors (including the seed tubes w/ sensors, radar, magnetic distance, SMM console and shaft rotation sensors) must be unplugged from the harness and/or console and the monitor must be off.

**NOTE:** If the monitor detects a radar sensor but no seed tubes at power up, it will automatically go into AREA COUNT mode. See “Area Counter/Speedometer Mode”.

**NOTE:** Disconnect magnetic distance sensor between MDS adapter and planter harness. DO NOT disconnect between MDS and MDS adapter.

01189909

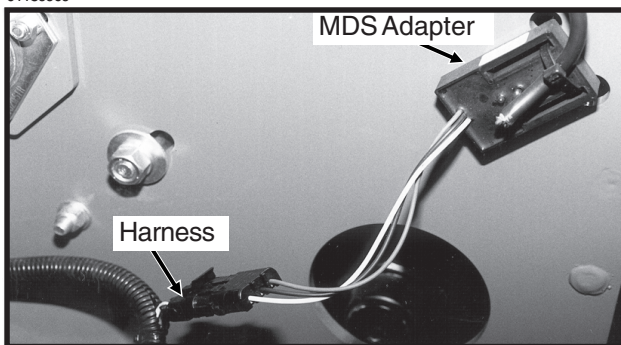

01189910



**STEP 2** Press the ON key. The monitor automatically enters the setup procedure. Monitor will scroll “NO SENSOR” on top LCD of KPM II Stack-Mode console.

**STEP 3** The monitor automatically defaults to rear/front. Press the SELECT key once for left/right and twice for four sections (front right/front left/rear right/rear left). The selected display will be solid and the configuration not currently selected will be flashing.

12060211

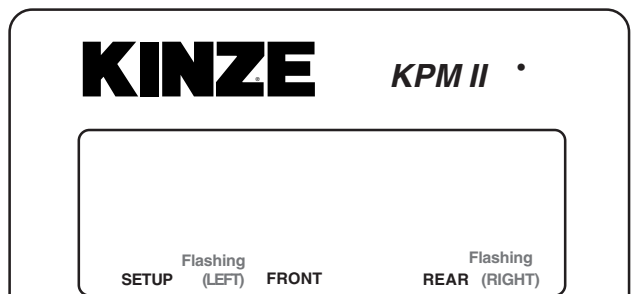

ROW	SETUP	SCAN
UNITS		SEED
SPEED		SEED
VOLUME		FIELD
		TOTAL

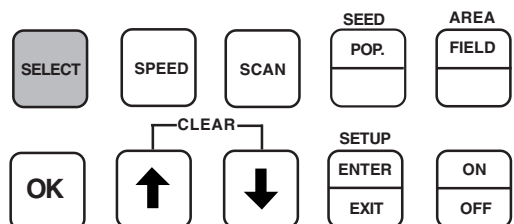

**NOTE:** SMM console may not be applicable to all models.

# KPM II STACK-MODE - PROGRAMMING/CONNECTING IS628 SMM CONSOLE, SHAFT ROTATION SENSORS, SEED TUBES AND/OR RADAR/MAGNETIC DISTANCE SENSORS

12060211

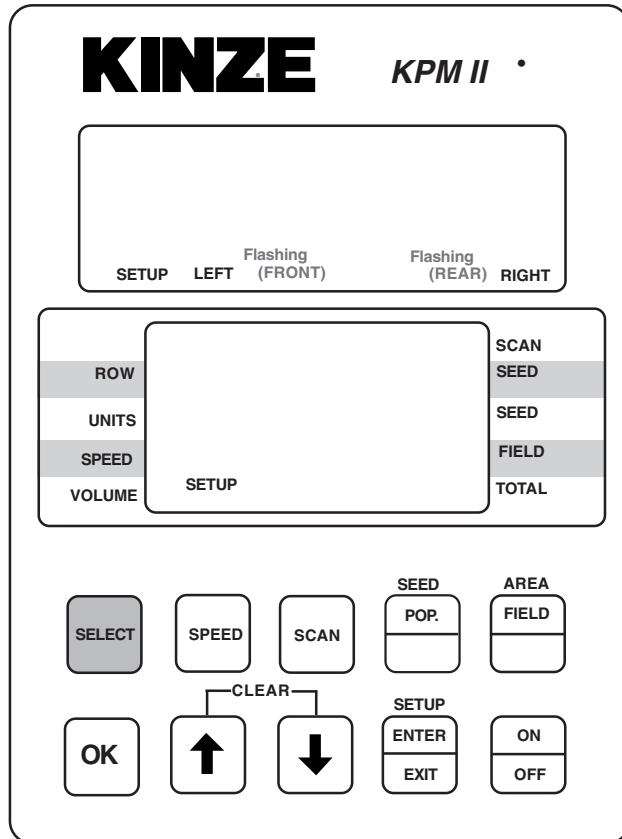

**NOTE: SMM console may not be applicable to all models.**

**NOTE: Model 3000, 3110, 3120, 3140, 3200, 3400, 3500, 3600, 3650 and 3700 (16 row) planters select the rear/front configuration. Model 3700 (24/36 row) and Model 3800 planters select left/right configuration.**

**STEP 4** Press and hold the OK key to confirm selection. The upper display will alternate between "NEW" and "SYS?".

The alarm will sound four short beeps followed by one long beep. At this point your selection has been saved and row numbers will appear flashing on the upper display of the KPM II.

12060211

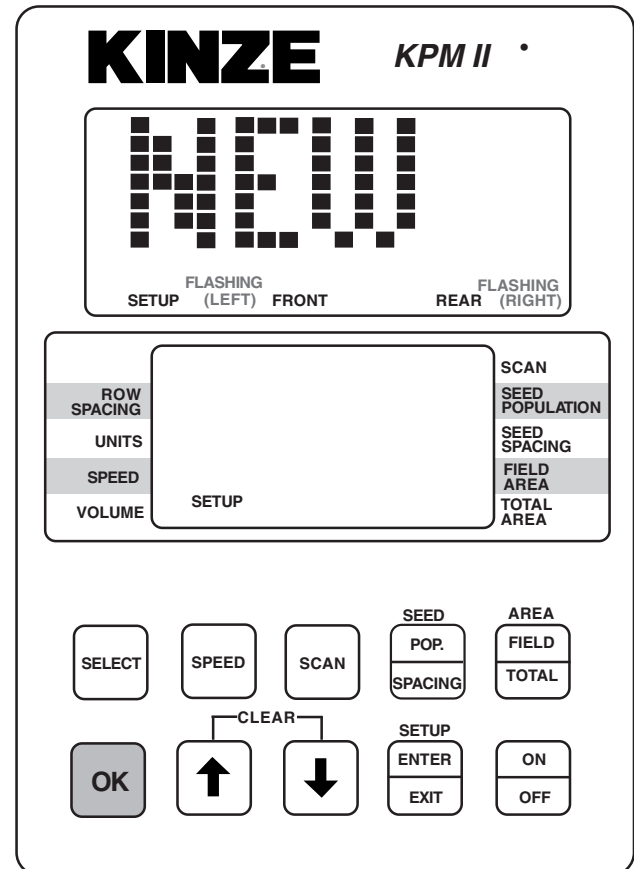

**NOTE: SMM console may not be applicable to all models.**

# KPM II STACK-MODE - PROGRAMMING/CONNECTING IS628 SMM CONSOLE, SHAFT ROTATION SENSORS, SEED TUBES AND/OR RADAR/MAGNETIC DISTANCE SENSORS

**NOTE: Illustrated using rear/front configuration.** The KPM II Stack-Mode console shows LEFT in the left/right configuration, REAR in the rear/front configuration and FRONT LEFT/REAR LEFT in the four sections configuration.

**STEP 5** (If Applicable) Connect SMM console into junction Y-harness which was installed between the KPM II Stack-Mode console and the primary harness. The SMM console will show a lighted screen and KPM will show on the lower LCD.

12060211



12060211

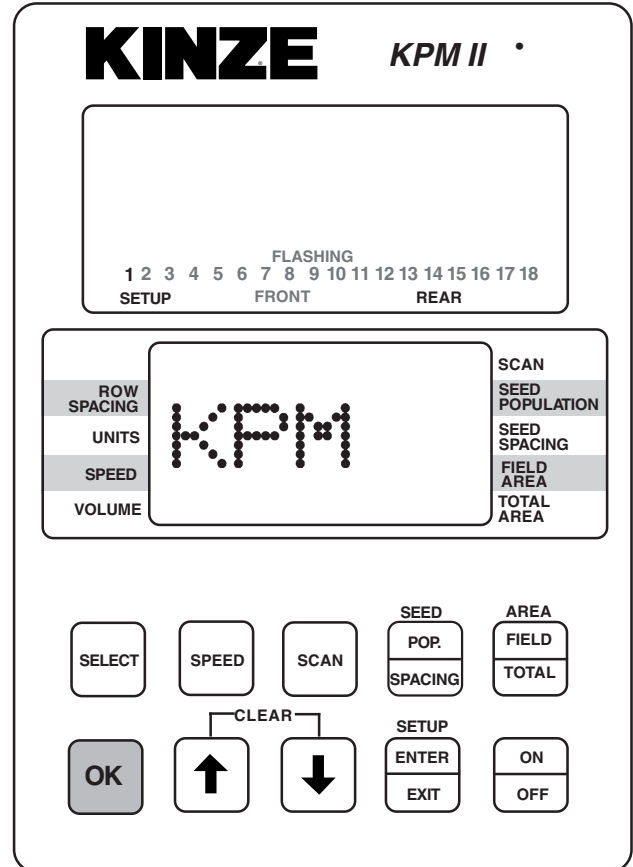
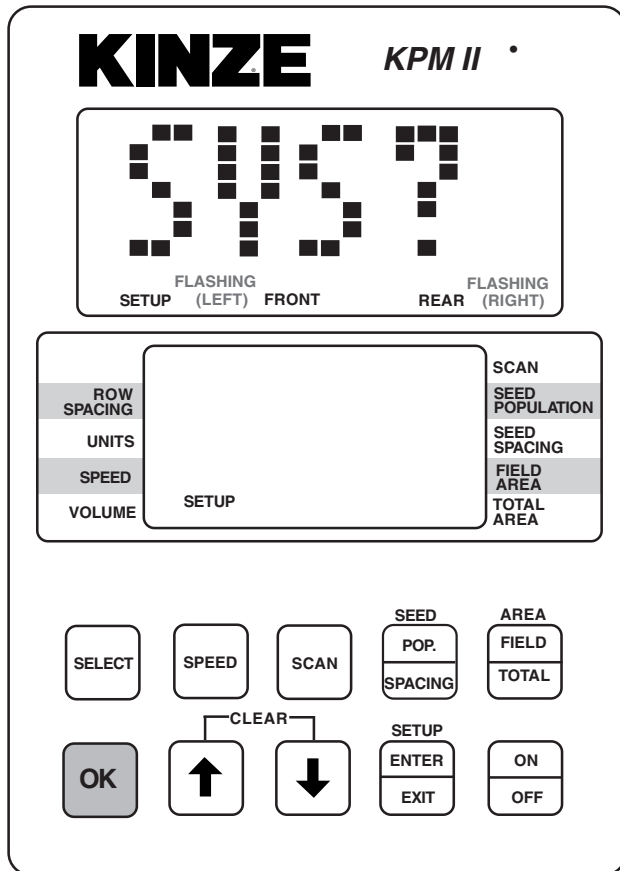

**NOTE: SMM console may not be applicable to all models.**

**NOTE: SMM console may not be applicable to all models.**

# KPM II STACK-MODE - PROGRAMMING/CONNECTING IS628 SMM CONSOLE, SHAFT ROTATION SENSORS, SEED TUBES AND/OR RADAR/MAGNETIC DISTANCE SENSORS

**STEP 6** If the monitor system includes shaft rotation sensors, these should be installed at this time. Plug in the L.H. shaft first, then the R.H. shaft. L.H. and R.H. is determined by facing in the direction the machine will travel when in use.

01189906

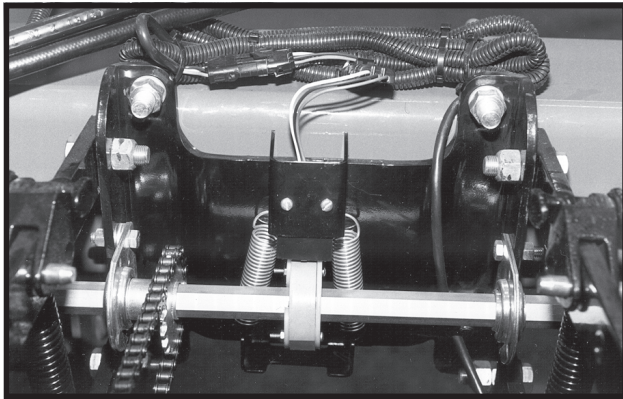

“LSHAFT” or “SHAFT 1” will display on the lower LCD when the first shaft rotation sensor is installed. “RSHAFT” or “SHAFT 2” will display when the second shaft rotation sensor is installed.

**NOTE: Illustrated using rear/front configuration. The KPM II Stack-Mode console shows LEFT in the left/right configuration, REAR in the rear/front configuration and FRONT LEFT/REAR LEFT in the four sections configuration.**

**MODEL 3800 PLANTERS** - The first shaft rotation sensor installed will be assigned to the rows on the outer L.H. half of the planter and the second shaft rotation sensor connected will be assigned to the rows on the inner L.H. half of the planter.

“SHAFT 1” will display on the lower LCD when the first shaft rotation sensor is installed. “SHAFT 2” will display when the second shaft rotation sensor is installed. “SHAFT 3” will display on the lower LCD when the third shaft rotation sensor is installed on the inner R.H. half of the planter. “SHAFT 4” will display when the fourth shaft rotation sensor is installed on the outer R.H. half of the planter.

12060211

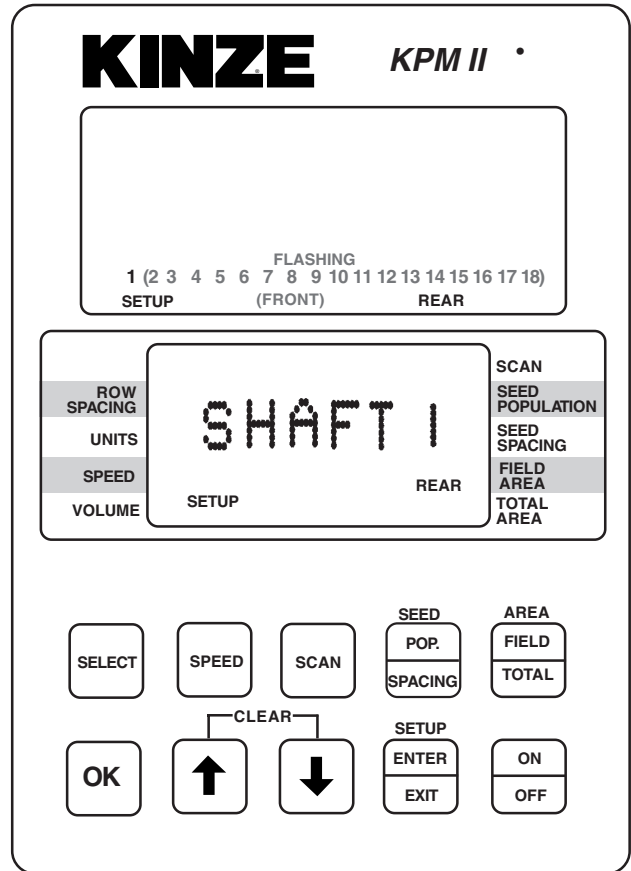

**NOTE: SMM console may not be applicable to all models.**

# KPM II STACK-MODE - PROGRAMMING/CONNECTING IS628 SMM CONSOLE, SHAFT ROTATION SENSORS, SEED TUBES AND/OR RADAR/MAGNETIC DISTANCE SENSORS

## STEP 6 (Continued)

12060211

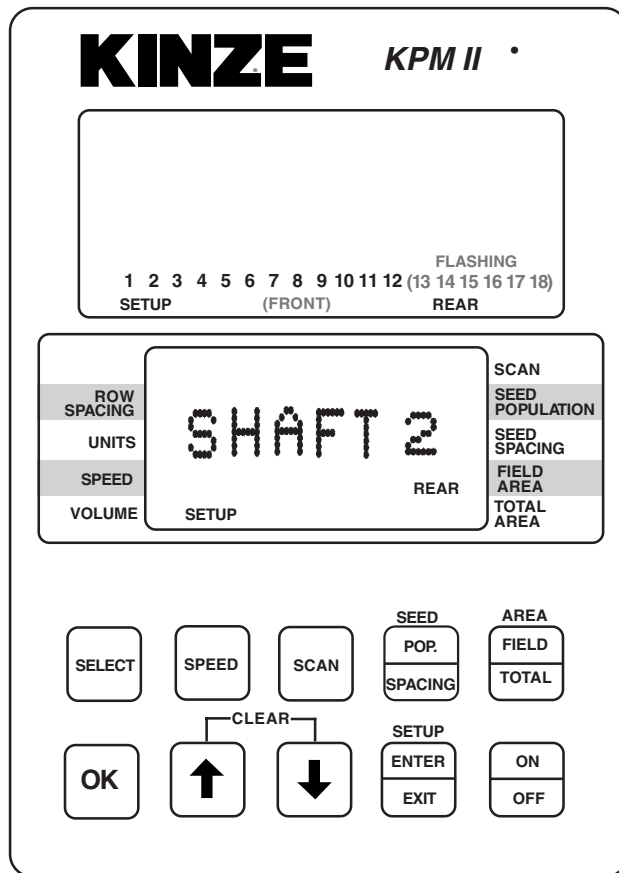

**NOTE: SMM console may not be applicable to all models.**

## STEP 7 Determine which row you want as number one and plug the seed tube w/sensor into the harness.

Continue plugging in sensors along with shaft rotation sensors if so equipped. Row 1 first, row 2 second and so on up to 18 rows. When a sensor is plugged in, the corresponding row number on the upper LCD display will stay solid, the monitor will chirp twice and a red LED (Light Emitting Diode) on the seed tube sensor will turn on for approximately 30 seconds to show connection is made.

(METR55b)

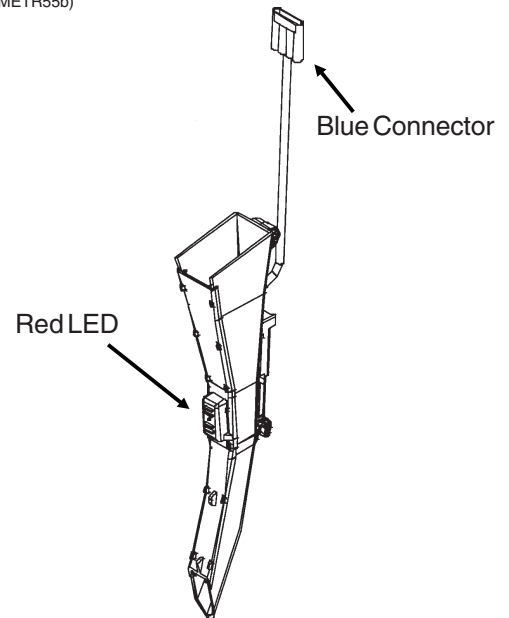

**NOTE: Illustrated using rear/front configuration. The KPM II Stack-Mode console shows LEFT in the left/right configuration, REAR in the rear/front configuration and REAR LEFT/FRONT LEFT in the four sections configuration.**

# KPM II STACK-MODE - PROGRAMMING/CONNECTING IS628 SMM CONSOLE, SHAFT ROTATION SENSORS, SEED TUBES AND/OR RADAR/MAGNETIC DISTANCE SENSORS

## STEP 7 (Continued)

12060211

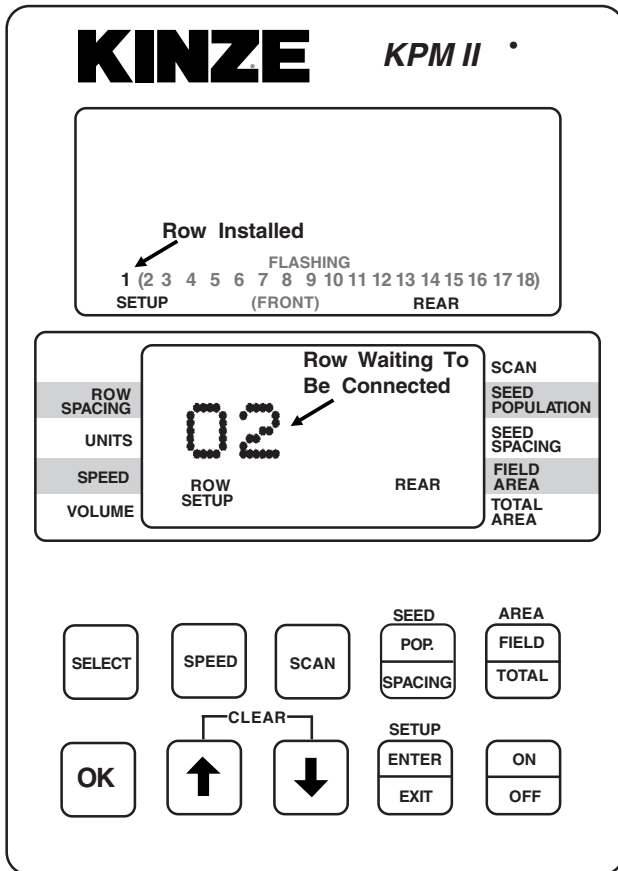

**NOTE: SMM console may not be applicable to all models.**

# KPM II STACK-MODE - PROGRAMMING/CONNECTING IS628 SMM CONSOLE, SHAFT ROTATION SENSORS, SEED TUBES AND/OR RADAR/MAGNETIC DISTANCE SENSORS

**STEP 8** When all the seed tubes for the current section (rear/front, left/right or four section) are installed, check to be sure the upper LCD on the KPM II Stack-Mode console displays solid numbers for the number of seed tubes connected. Press and hold the OK key to save the setup for the current section. The SAVE? icon will display followed by continuous short beeps indicating the monitor is preparing to save. The installer has 5 seconds to decide to save the current configuration. During this time, four short beeps will sound followed by a long beep and the SAVE? icon will turn off and the word "DONE" shows on the screen. The monitor will continue to the second section installation (If Applicable).

**NOTE: Illustrated using rear/front configuration. The KPM II Stack-Mode console shows LEFT in the left/right configuration, REAR in the rear/front configuration and FRONT LEFT/REAR LEFT in the four sections configuration.**

12060211

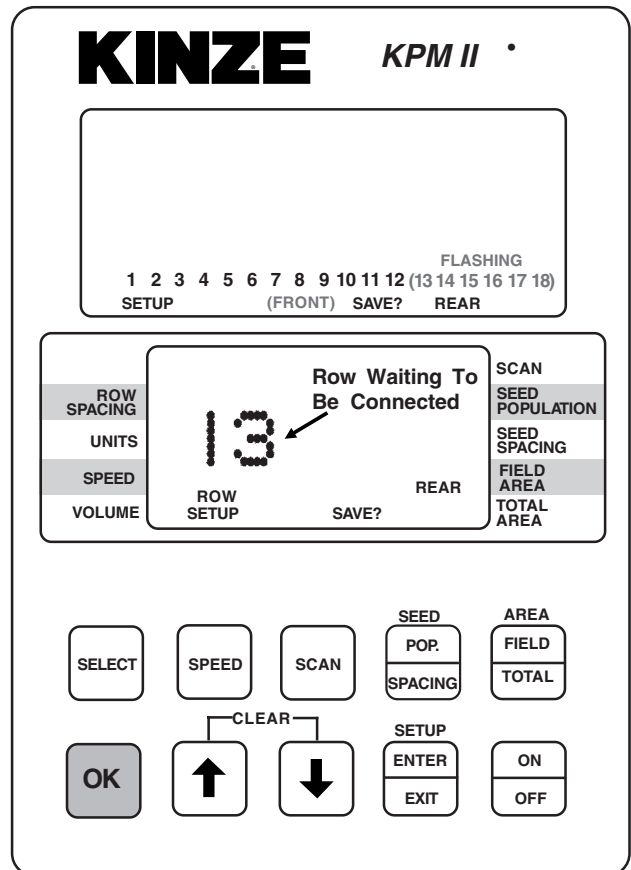

**NOTE: SMM console may not be applicable to all models.**

# KPM II STACK-MODE - PROGRAMMING/CONNECTING IS628 SMM CONSOLE, SHAFT ROTATION SENSORS, SEED TUBES AND/OR RADAR/MAGNETIC DISTANCE SENSORS

## STEP 8 (Continued)

12060211

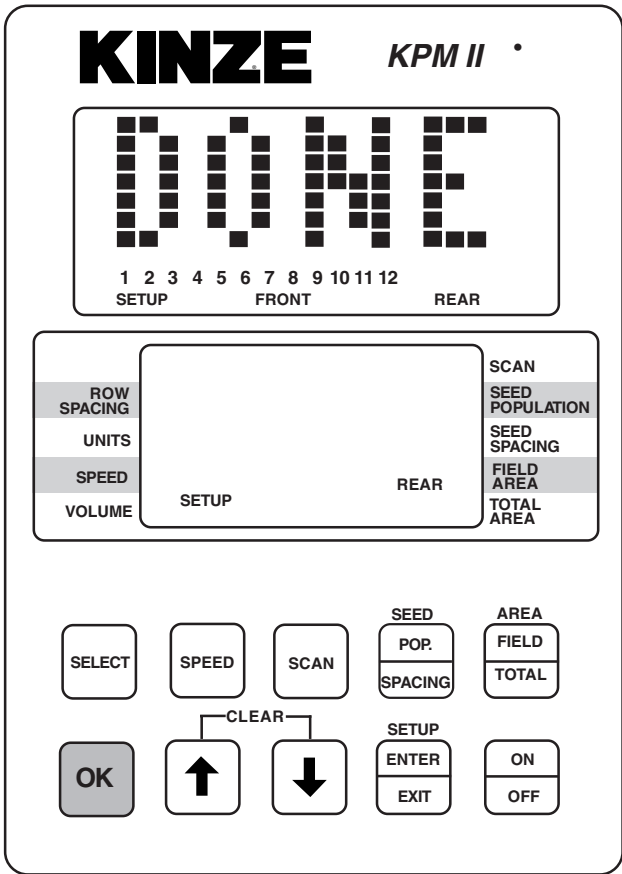

**NOTE: SMM console may not be applicable to all models.**

# KPM II STACK-MODE - PROGRAMMING/CONNECTING IS628 SMM CONSOLE, SHAFT ROTATION SENSORS, SEED TUBES AND/OR RADAR/MAGNETIC DISTANCE SENSORS

**STEP 9** Follow STEPS 6, 7 and 8 to install the second, third and fourth sections (If Applicable). If no seed tubes are installed on additional sections, press and hold the OK key. The word “DONE” will appear on upper display. The alarm will sound four short beeps followed by one long beep and the SAVE? icon turns off. The monitor has exited the setup mode. When you release the OK key the upper display will scroll “WAITING CALIBRATION”. The lower display will show “GNDSPD” and the alarm will sound continually until the distance sensor is connected. See STEP 10.

**NOTE:** The SMM console LCD remains blank (except the backlighted screen) until the entire system is saved.

**NOTE:** Illustrated using rear/front configuration. The KPM II Stack-Mode console shows LEFT in the left/right configuration, REAR in the rear/front configuration and FRONT LEFT/REAR LEFT in the four sections configuration. The SMM console shows RIGHT in the left/right configuration, FRONT in the front/rear configuration and FRONT RIGHT/REAR RIGHT in four sections configuration.

12060212

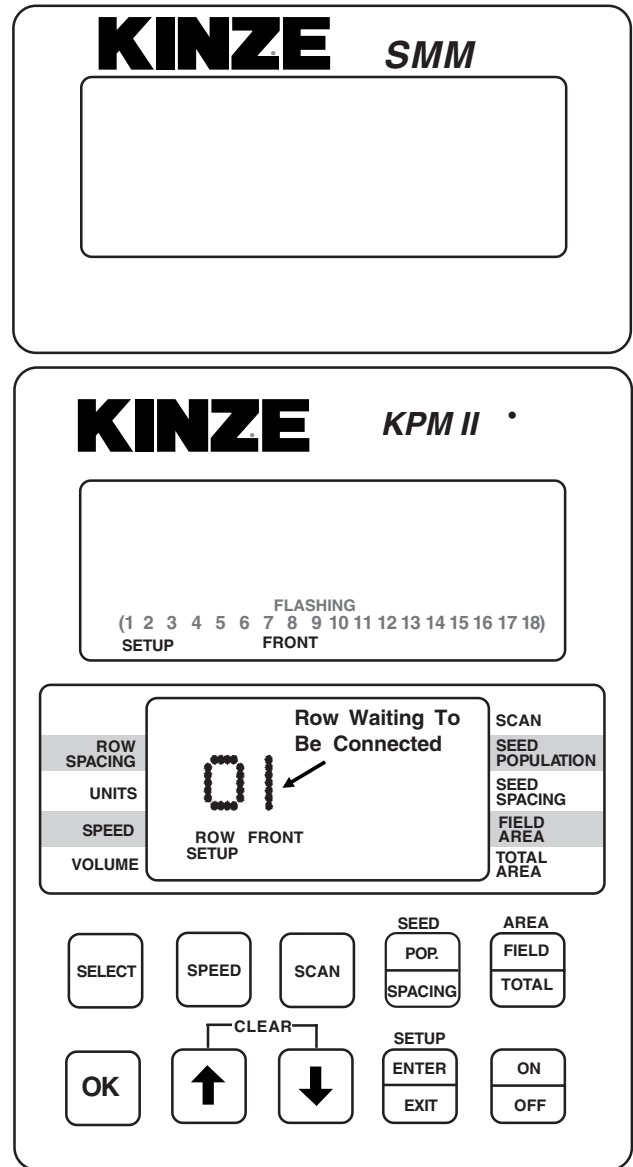

**NOTE:** SMM console may not be applicable to all models.

# KPM II STACK-MODE - PROGRAMMING/CONNECTING IS628 SMM CONSOLE, SHAFT ROTATION SENSORS, SEED TUBES AND/OR RADAR/MAGNETIC DISTANCE SENSORS

## STEP 9 (Continued)

12060213



12060214

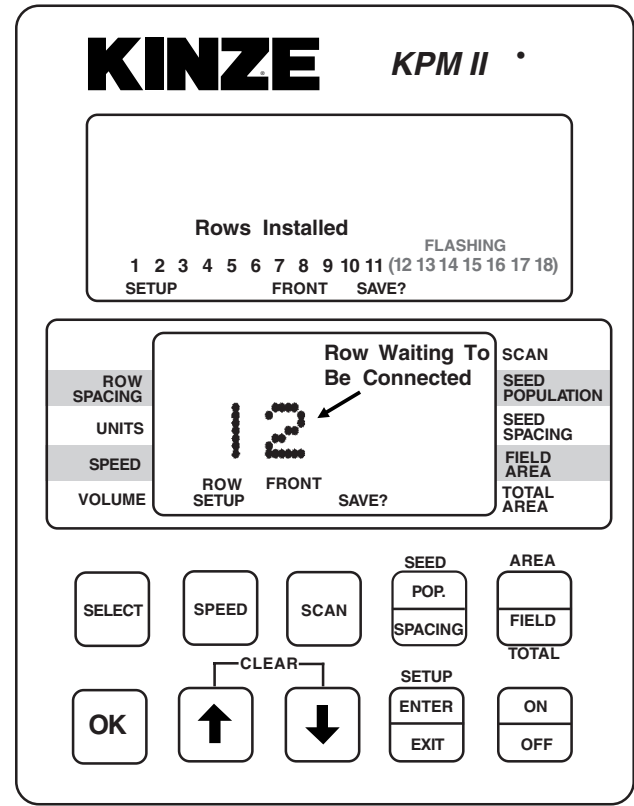
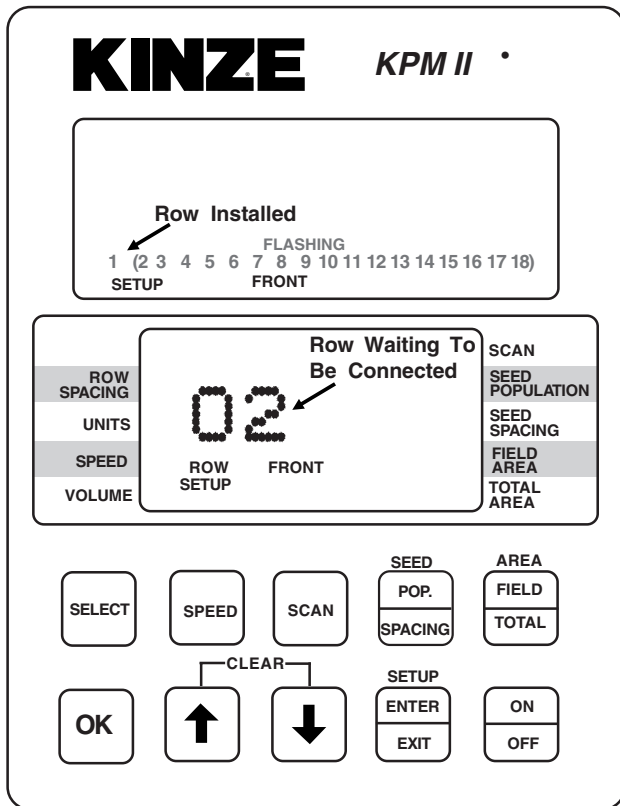

NOTE: SMM console may not be applicable to all models.

NOTE: SMM console may not be applicable to all models.

# KPM II STACK-MODE - PROGRAMMING/CONNECTING IS628 SMM CONSOLE, SHAFT ROTATION SENSORS, SEED TUBES AND/OR RADAR/MAGNETIC DISTANCE SENSORS

## STEP 9 (Continued)

12060215

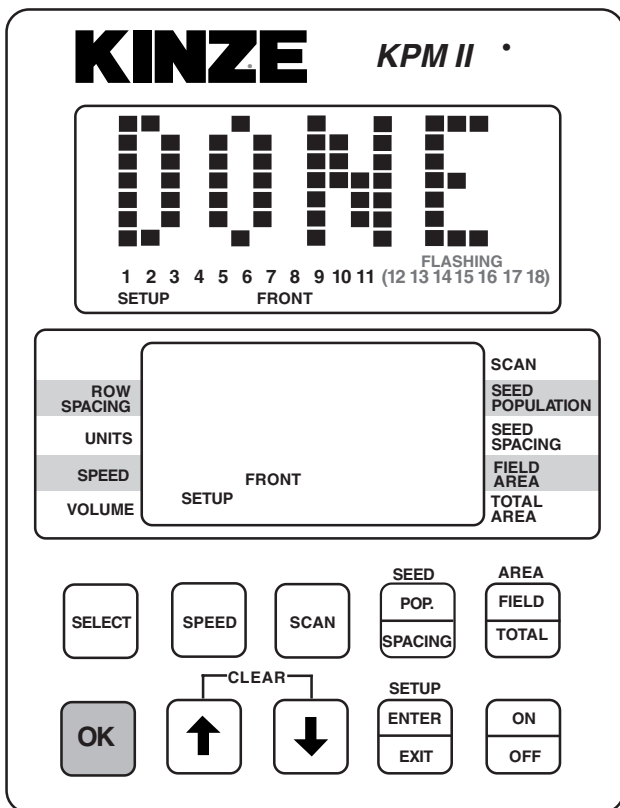

**NOTE: SMM console may not be applicable to all models.**

**STEP 10** With the lower display showing "GNDSPD", connect the distance sensor. The monitor will display "PICKUP" if a magnetic distance sensor is connected or "RADAR" if a radar distance sensor is installed. Only one distance sensor can be connected at a time.

**NOTE: Illustrated using rear/front configuration.** The KPM II Stack-Mode console shows LEFT in the left/right configuration, REAR in the rear/front configuration and FRONT LEFT/REAR LEFT in the four sections configuration. The SMM console shows RIGHT in the left/right configuration, FRONT in the rear/front configuration and FRONT RIGHT/REAR RIGHT in four sections configuration.

**NOTE: To connect the radar distance sensor, install the 10" monitor/radar adapter between the console and radar distance sensor to adapt the monitor system to various tractor radar systems. DO NOT CONNECT 10" MONITOR/RADAR ADAPTER PRIOR TO THIS STEP.**

# KPM II STACK-MODE - PROGRAMMING/CONNECTING IS628 SMM CONSOLE, SHAFT ROTATION SENSORS, SEED TUBES AND/OR RADAR/MAGNETIC DISTANCE SENSORS

## STEP 10 (Continued)

12060216

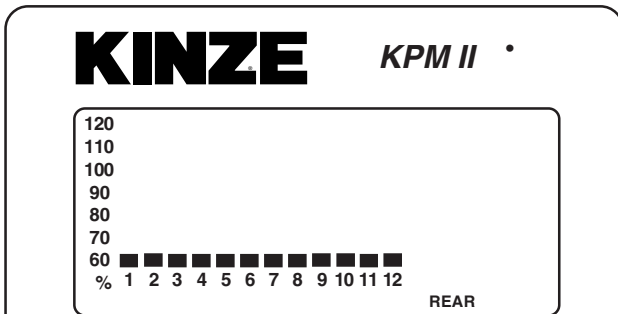
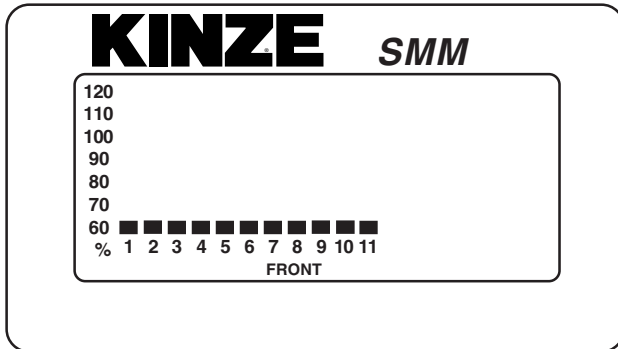

**KINZE KPM II**

ROW SPACING	GNDSPD	SCAN
UNITS		SEED POPULATION
SPEED		SEED SPACING
VOLUME		FIELD AREA
		TOTAL AREA

REAR

SELECT SPEED SCAN SEED POP. SPACING AREA FIELD TOTAL

OK CLEAR UP DOWN SETUP ENTER EXIT ON OFF

**NOTE: SMM console may not be applicable to all models.**

**NOTE: To reprogram the system to monitor more or less rows (up to the maximum of 18 per section, 72 total in four section configuration), all sensors must be unplugged, followed by the complete setup procedure.**

**NOTE: Individual seed tubes may be unplugged for special situations. An alarm will sound which can be silenced by touching the OK key. The monitor will recognize the seed tube(s) when reconnected.**

12060217

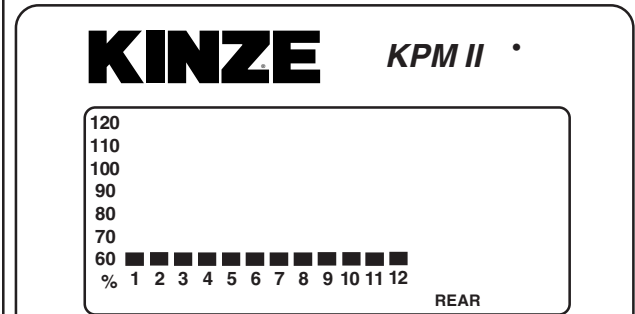
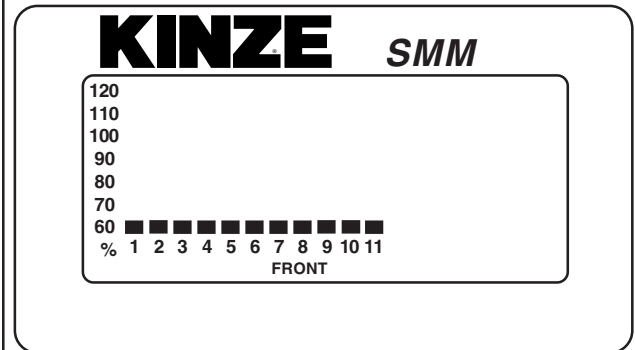

**KINZE KPM II**

ROW SPACING	MPH	0.0	SCAN
UNITS			SEED POPULATION
SPEED			SEED SPACING
VOLUME			FIELD AREA
			TOTAL AREA

SELECT SPEED SCAN SEED POP. SPACING AREA FIELD TOTAL

OK CLEAR UP DOWN SETUP ENTER EXIT ON OFF

**NOTE: SMM console may not be applicable to all models.**

**CONSOLE, SHAFT ROTATION SENSORS, SEED TUBES  
AND/OR RADAR/MAGNETIC DISTANCE SENSORS**

---

**NOTE: See “Programming - Row Spacing”, in the Operation Section, for programming applicable row spacing.**

## KPM I ELECTRONIC SEED MONITOR

(MTR28)

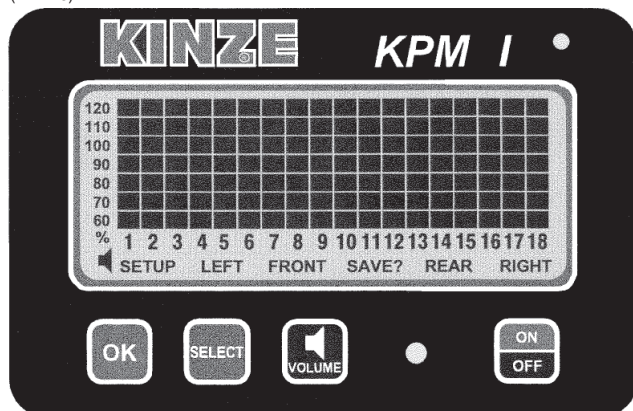

The electronic seed monitor system consists of a console, which is mounted on the tractor; seed tubes with computerized sensors, one of which is installed in each planter row unit; a primary harness\*, which connects the console to the planter harness; and a planter harness (junction Y-harness and/or harness extension where applicable), to which the individual seed tube sensors connect.

Seed flow for up to 36 rows, in two 18 row sections (left/right or rear/front), may be monitored with one monitor. For less complicated applications (18 rows or less), all rows may be programmed in one section and the other section left disabled.

The monitor system is powered by the tractor battery (requires 12 volts DC). The console receives information from each of the sensors and translates this information.

The single backlit Liquid Crystal Display (LCD) shows the active section, the number of monitored rows per section, the relative seed rate for each row (using a bar graph display) and scrolls various alarm and warning messages when an alarm condition exists. A continuous audible alarm will sound upon system malfunction or underflow conditions for any monitored row. Alarms must be acknowledged by the user. Various warnings may sound the alarm or flash one or more icons.

The monitor will power down if no activity is detected within one hour. No activity means there has been no new seed flow and no operator push key input. (If Applicable)

**\* NOTE: The primary harness, on all 3000 Series Planters, is hard-wired into the safety/warning light harness or control console harness included as standard equipment with the planter.**

Monitor Key Functions .....	51
LCD Functions .....	51
Changing The Audible Alarm Volume .....	52
Warnings And Alarms .....	52
Replacing A Faulty Sensor .....	53
Field Operation .....	54
Programming/Connecting Seed Tubes .....	54

### MONITOR KEY FUNCTIONS

Each key press is acknowledged by the monitor with a short beep.

#### OK

- Ends and saves the new setup during installation.
- Acknowledges and silences alarms in the operation mode.

#### SELECT

- Selects the application mode (rear/front or left/right) at the beginning of installation setup.
- Selects the active section(s) (rear, rear/front, left, right or left/right) in the operation mode.
- Has no affect on a system configured to monitor only one section.

#### VOLUME

- Pressing the key will turn the audible alarm on.
- Holding the key for periods of 2 seconds increases the volume until it reaches the maximum, at which time it rolls over to the minimum level.

#### ON/OFF

- Powers the unit on and off.

### LCD FUNCTIONS

The monitor collects data on the planting rates from all active rows and calculates an average. This average will determine the 100% mark. Seed rate for each row is then compared to the average value and the result is displayed on the bar graph.

The information regarding each section is displayed alternately every 5 seconds. While operating a system with two sections programmed, one or both sections may be selected any time. When only one section is selected, the monitor calculates the average based on the remaining active rows from that section.

**STEP 1** Press SELECT key once to show one section. The flashing icon shows the section that is not selected. The selected section is continuously displayed on the LCD.

**EXAMPLE:** The system is setup to display rear/front sections. Press **SELECT** key. The **FRONT** icon will be flashing and the **REAR** section will be displayed on the bar graph. After 1 minute the **FRONT** icon will stop flashing. The monitor will stay in this **REAR** only display through power down and power up. Each time the monitor is turned on while in **REAR** only mode, the **FRONT** icon will flash for 1 minute. Also if seed flow is sensed in the **FRONT** section while planting, the **FRONT** icon will resume flashing.

**STEP 2** Press **SELECT** key again to activate both sections.

**EXAMPLE:** Press **SELECT** key a second time. The information regarding each section will display alternately every 5 seconds.

For simple applications, where only one section is programmed, the display will automatically lock on that section. Pressing **SELECT** key will have no affect.

**NOTE:** When alternating between two sections, the display will lock on the section containing the first recognized alarm until the alarm is acknowledged by pressing the **OK** key or the alarm condition is removed.

## CHANGING THE AUDIBLE ALARM VOLUME

**STEP 1** Press and hold down the **VOLUME** key.

**STEP 2** The **SETUP** and **VOLUME** icons will turn on and the alarm will sound continuously. The intensity of the sound will change every 2 seconds. After the maximum volume is reached, the next change will set the volume to minimum and will continue to get louder every 2 seconds. When the desired volume is reached, release the key.

## WARNINGS AND ALARMS

- 1. System Alarms** - A system alarm is activated when the monitor detects a faulty sensor or one of several other communication faults.

The corresponding row number starts flashing and the alarm sounds. All segments on the corresponding bar graph are turned off. Pushing the **OK** key to acknowledge the warning will turn the audible alarm off. The row number will continue to flash until the alarm condition is removed. If the monitor detects a faulty sensor and there is no planting activity present, the monitor will scroll "CHECK CONNECTION".

Another type of system alarm occurs when the monitor detects a data communication bus error. The three possible data communication bus errors are:

LCD Display	Error Condition
SYS HI	The data communication lead (green) has been shorted to the power lead (white).
SYS LO	The data communication lead (green) has been shorted to the ground lead (black).
SYS EC	An internal error has been detected.

- 2. Under Flow Alarms** - If the seed rate for one or more rows is less than 55% of the calculated average, the corresponding 60% segment will stay on, the corresponding row number starts flashing and the alarm sounds. Pushing the **OK** key to acknowledge the alarm will turn the alarm off. The 60% segment of the bar graph remains on and the row number continues to flash until the alarm condition is corrected.

**NOTE:** All alarms present within a short time before planting stops, are frozen on the screen and the text **LOW** or **FAIL** will display on the LCD. If the under flow is between 0% and 10%, this warrants a "FAIL" condition. If the under flow is between 10% and 55%, a "LOW" condition is generated. If multiple rows have an under flow condition, "FAIL" will display if any one or more rows is between 0% and 10%. This allows the user to identify and fix the problem rows.

**NOTE: This warning will not trigger unless a minimum time of continuous planting has passed.**

**NOTE: If all the rows show a seed rate of zero, the condition will not generate an alarm. It will be assumed the planter has stopped. The row numbers and the bottom 60% segment will remain on for all selected rows.**

3. **Multiple Alarms** - If more than one alarm condition occurs at the same time, pushing the OK key will acknowledge all alarms that are currently displayed. For example, if one row on the front and one row on the rear are alarming, pushing the OK key will only acknowledge one of them. However, if there are two alarms on the front, both alarms would be acknowledged with one push of the OK key.
4. **Section Not Selected Warning** - If the monitor was programmed for two sections and only one is currently selected for display (by pressing the SELECT key), the icon of the disabled section will flash for a period of 1 minute, then turn off at each power up. If seed flow is sensed in the disabled section, the icon for that section (front, left or right) will begin to flash.
5. **Seed Planting Stopped Warning** - When the monitor detects no seed flow on all rows, the monitor will emit 3 short beeps to alert the user. This warning will occur each time the planter is stopped, each time the planter is raised at the end of a row or if the mechanical drive fails while planting.

**NOTE: This warning will not trigger unless a minimum time of continuous planting has passed.**

6. **Seed Counting Sensor In Calibration Warning** - All seed counting sensors run a self-calibration sequence on power up. While in calibration the bottom segment of each corresponding bar graph will flash if the monitor detects movement or planting activity. If the monitor does not detect this, the message "WAIT CALIBRATION" will be scrolled.

7. **Seed Counting Sensor Too Dirty Warning** - After the seed counting sensors end their internal self-calibration, the monitor may detect one or more sensors are either too dirty or blocked. If the monitor detects planting or movement, the corresponding bar graph remains flashing. The monitor will display "CLEAN SENSORS" on the LCD if no movement or planting is detected, prompting the user to clean the tubes. If the tubes are dirty, they will still show seed flow with less accuracy. If the tubes are blocked the user will get an alarm as soon as planting starts. The corresponding bar graph will remain flashing until the problem is corrected and the monitor is powered down and then powered back up.
8. **Low Battery Warning** - The monitor is constantly monitoring its input voltage to quickly detect low power conditions. If the monitor detects that the input voltage has dropped below 11.0V, it will display "LOW POWER" on the LCD, provided that the monitor does not detect planting.

**NOTE: After the alarms have been acknowledged and if the alarm condition is still present, the LCD will continue to display the alarm condition.**

REPLACING A FAULTY SENSOR
---------------------------

To replace a faulty sensor; (a) disconnect the faulty sensor and check the monitor to be sure the correct sensor was disconnected, (b) turn the monitor off, (c) after a few seconds, turn the monitor back on and (d) plug in the replacement sensor. The monitor will chirp twice to acknowledge the new sensor was learned and saved.

To replace more than one faulty sensor, proceed as stated above beginning with the lowest numbered row in the rear or left section and continue to replace sensors in increasing order. Then move on to the front or right section and continue in ascending row number order.

**NOTE: If the monitor is not turned off and then on, the replacement sensor(s) will be ignored until the next power on, at which point they will be randomly learned by the monitor.**

## FIELD OPERATION

(MTR28e/MTR28c/MTR28d/MTR28b)

Press the ON/OFF key to turn the monitor on and off.



Information regarding each section is displayed alternately every 5 seconds.

### REAR/FRONT CONFIGURATION

- Press the SELECT key once to show REAR section only.
- Press the SELECT key a second time to return to each section being displayed alternately every 5 seconds.
- Press the SELECT key a third time to show REAR section only again.



### LEFT/RIGHT CONFIGURATION

- Press the SELECT key once to show LEFT section only.
- Press the SELECT key a second time to show RIGHT section only.
- Press the SELECT key a third time to return to each section being displayed alternately every 5 seconds.



**NOTE: SELECT key has no function when only a single section is being used.**

Press the VOLUME key to increase or decrease volume. See “Changing The Audible Alarm Volume”.



Press the OK key to silence alarms. See “Warnings And Alarms”.



## PROGRAMMING/CONNECTING SEED TUBES

**STEP 1** All the seed tubes w/sensors must be disconnected from the harness and the monitor must be off.

**STEP 2** Press the ON key. The monitor automatically enters the setup procedure. If the monitor was accidentally powered on with no sensors attached, the user can turn the monitor off at this point and the previous configuration is not lost.

**STEP 3** Press the SELECT key. Each time you press the SELECT key the mode will toggle between rear/front and left/right. The selected display will be solid and the configuration not currently selected will be flashing. By default the monitor starts in rear/front mode.

01229910

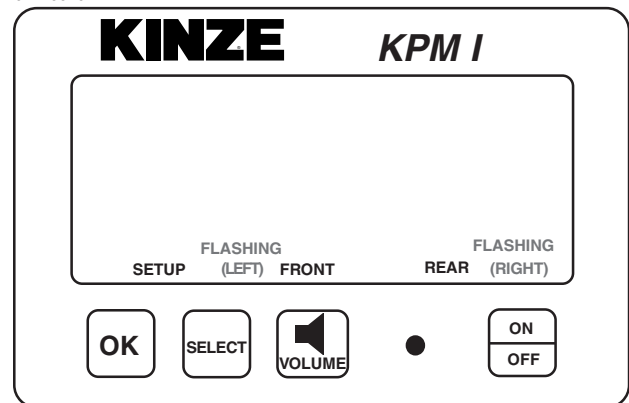

01229911

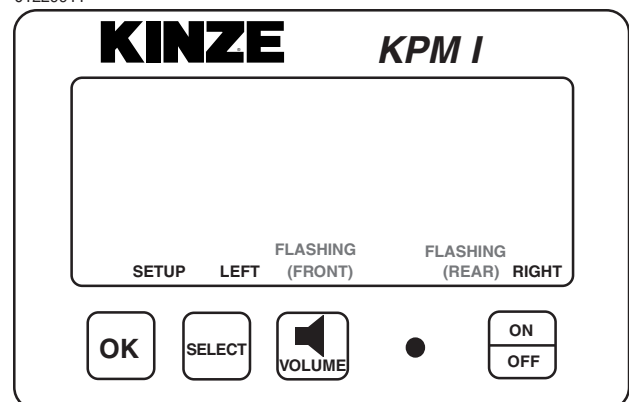

**NOTE: Model 3700 (24/36 row) planters will use the left/right configuration. Models 3000, 3110, 3120, 3140, 3200, 3400, 3500, 3600/3650 and 3700 (16 row) planters will use the rear/front configuration only. When all rows can be viewed on a single display (rear), pressing the select key has no function.**

**STEP 4** Press and hold the OK key to confirm the selection and continue holding until the row numbers appear on the display. During confirmation, the display will alternate between “NEW” and “SYS” to alert the user that the previous configuration will be lost. With the rear/front mode selected, the monitor automatically starts with the rear section. The REAR icon shows solid and the FRONT icon starts to flash. With the left/right mode selected, the monitor automatically starts with the left section. The LEFT icon shows solid and the RIGHT icon starts to flash.

01229912

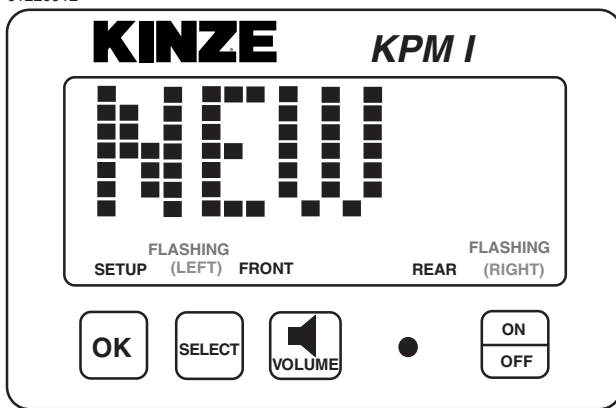

**STEP 5** Plug each seed tube w/sensor into the harness in a predetermined order. Row 1 first, row 2 second and so on up to 18 rows. When a sensor is plugged in, the corresponding row number on the LCD display will stay solid, the monitor will chirp twice and the LED (Light Emitting Diode) on the seed tube sensor will turn on for approximately 30 seconds to show connection is made. NOTE: Unless there is a faulty sensor, the installer should just have to connect the sensors in the proper order without checking the monitor is acknowledging each sensor.

01229915

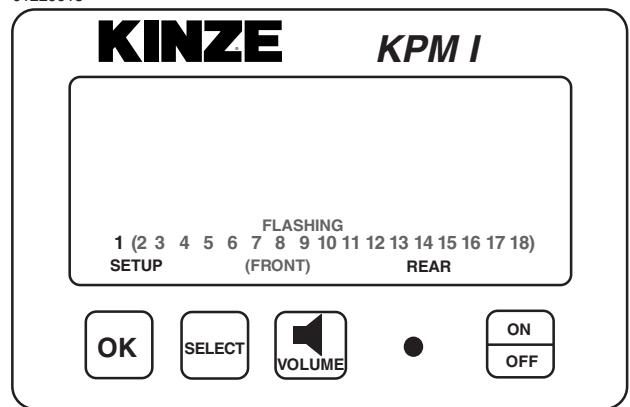

01229912a

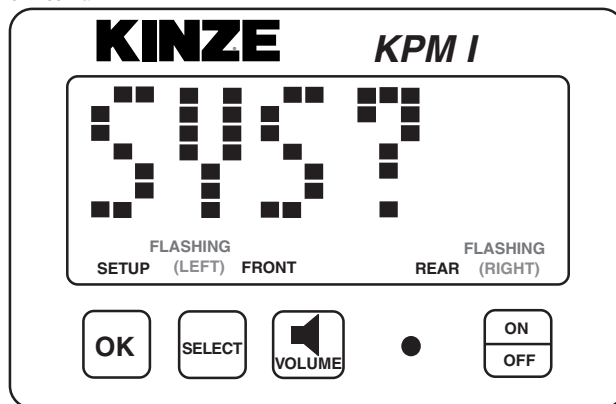

**STEP 6** When all the seed tubes w/sensors for the current section are installed, check to be sure the monitor displays solid numbers for the number of sensors connected.

01229916

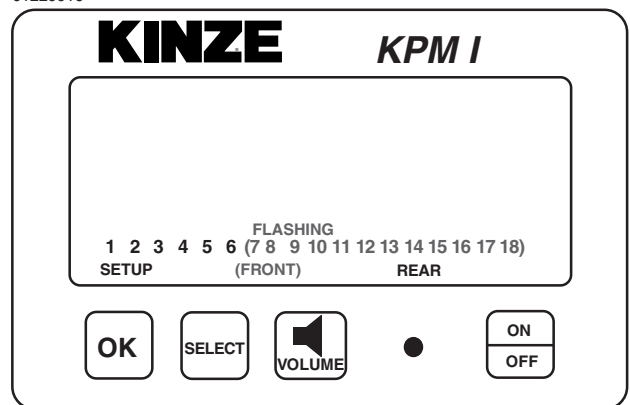

**STEP 7** If this condition is satisfied, press and hold the OK key to save the setup for the current section. The SAVE? icon will show followed by continuous short beeps indicating the monitor is preparing to save. The installer has 5 seconds to decide if he wants to save the current configuration. During this time the short beeps will sound. To complete the save, hold the OK key pressed until the word “DONE” shows on the screen followed by a long beep and the SAVE? icon turns off. When the OK key is released the monitor will continue with the second section installation.

**STEP 8** Follow STEPS 5 through 7 to install the second section. If no seed tubes are installed on the second section, press and hold the OK key until the word “DONE” shows on the screen followed by a long beep and the SAVE? icon turns off.

01229917

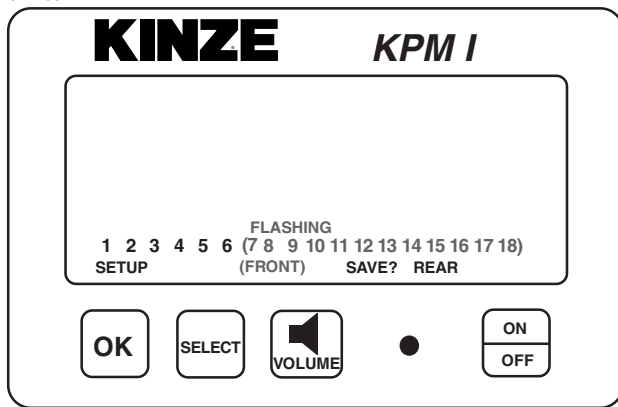

01229919

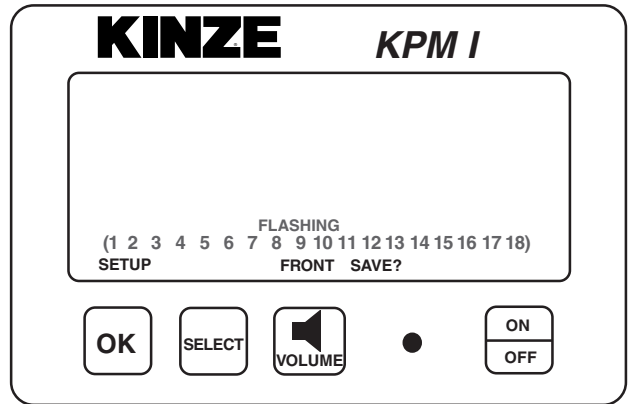

01229920

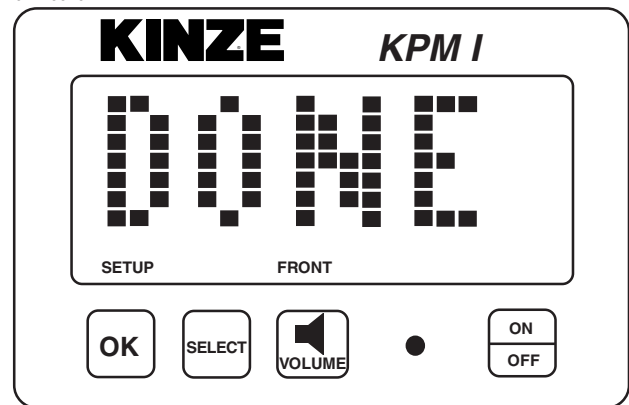

01229918

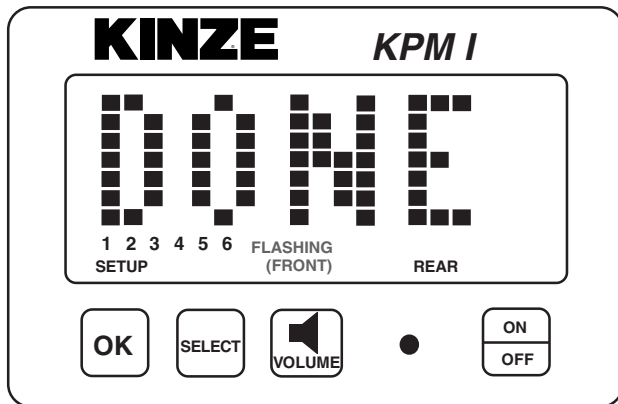

**NOTE:** Individual seed tubes may be unplugged for special situations. An alarm will sound which can be silenced by touching the OK key. The monitor will recognize each seed tube when reconnected.

**KPM II STACK-MODE ELECTRONIC SEED MONITOR**

(MTR41e)

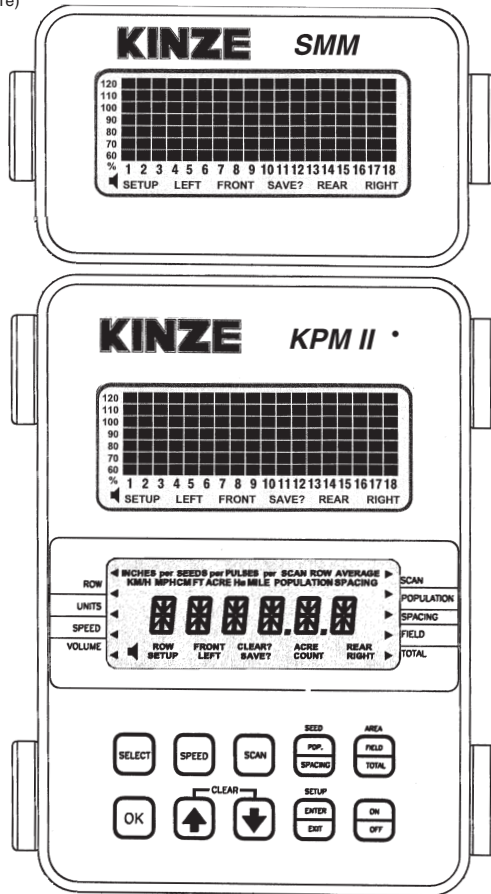

**NOTE: SMM console may not be applicable to all models.**

The KPM II Stack-Mode electronic seed monitor system consists of (a) a KPM II Stack-Mode console, which is mounted on the tractor; (b) seed tubes with sensors, one of which is installed in each planter row unit; (c) a magnetic distance sensor, which is installed on the planter, or a radar distance sensor, which is installed on the tractor; (d) shaft rotation sensors, which are installed on the planter drill shafts; and (e) a planter harness (junction Y-harness and/or extension harness where applicable), to which the individual seed tube sensors connect. The primary harness, which connects the monitor console to the planter harness, is hard-wired into the safety/warning light harness or control console harness included as standard equipment with the planter.

The software design of the KPM II Stack-Mode console allows the use of an add-on SMM console for simultaneous viewing of the seed flow bar graphs for standard and/or Interplant® System rows (up to 36 rows in two sections). A total of 72 rows may be displayed in

multiple sections (rear/front, left/right or four sections). The SMM console must be used to allow utilization of the four section feature.

The SMM console is included with the KPM II Stack-Mode Electronic Seed Monitor Package for 24 and 36 row Model 3700 planters and all Model 3800 planters. It is available as a separate package for use when 3400, 3600 or 3650 planters are equipped with Interplant® Package rows.

The monitor system is powered by the tractor battery (requires 12 volts DC). The console receives information from each of the sensors and translates this information.

The KPM II Stack-Mode console has two backlit Liquid Crystal Displays (LCD). The upper display shows the active section, the number of monitored rows per section, the relative seed rate for each row (using a bar graph display) and scrolls various alarm and warning messages when an alarm condition exists. A continuous audible alarm will sound upon system malfunction or underflow conditions for any monitored row. Alarms must be acknowledged by the user. Various warnings may sound the alarm or flash one or more icons. The lower display is used to display alphanumeric data such as row spacing, units (Metric or English), speed, volume, seed population, seed spacing, field area, total area and distance sensor pulses per mile/kilometer.

The SMM console has one backlit Liquid Crystal Display (LCD) which functions the same as the upper display on the KPM II Stack-Mode console except it does not scroll alarm and warning messages. The SMM console must be programmed into the system before printed text will display on the LCD.

The monitor system will power down if no activity is detected within one hour. No activity means there has been no new seed flow and no operator push key input.

<b>Monitor Key Functions</b> .....	<b>58</b>
<b>Upper LCD Functions</b> .....	<b>69</b>
<b>Lower LCD Functions</b> .....	<b>60</b>
<b>Programming</b>	
<b>Changing The Audible Alarm Volume</b> .....	<b>62</b>
<b>Units (Metric Or English)</b> .....	<b>63</b>
<b>Row Spacing</b> .....	<b>63</b>
<b>Speed</b> .....	<b>65</b>
<b>Clearing Total Area</b> .....	<b>66</b>
<b>Area Counter/Speedometer Mode</b> .....	<b>67</b>
<b>Warnings And Alarms</b> .....	<b>67</b>
<b>Replacing A Faulty Sensor</b> .....	<b>68</b>
<b>Field Operation</b> .....	<b>69</b>
<b>Clearing Field Area</b> .....	<b>70</b>
<b>Programming/Connecting SMM Console, Shaft Rotation Sensors, Seed Tubes And/Or Radar/Magnetic Distance Sensors</b> .....	<b>71</b>
<b>Row-By-Row Alarm Level Setting</b> .....	<b>83</b>

MONITOR KEY FUNCTIONS
-----------------------

Push keys allow the user to select or change the operating mode, the active displays or the current configuration. Depending on the operating mode or the current display selected, some keys are valid while some are not. Each key press, if valid, is acknowledged by a short beep and an action is taken. If the key press has no action associated, the key press is considered invalid, and the user will not get any feedback.

**SELECT**

- Selects the application mode (rear/front, left/right or four sections up to a maximum of 72 rows) at the beginning of installation in the setup mode.
- Selects the active section(s) (rear, rear/front, left, right or left/right) in the operation mode.
- Has no affect on a system configured to monitor only one section.
- While programming the monitor, the key will select the digit to change.

**SPEED**

- Immediately displays the current ground speed.

**SCAN**

- If the current average population or average spacing is displayed, this key sequentially displays the seed population/spacing on each row.
- If the display shows functions other than average seed population or spacing, pressing SCAN will sequentially display speed, average seed population and average seed spacing.
- Pressing a second time freezes the display on the current row.
- Pressing a third time restarts the sequential display.

**SEED POPULATION/SEED SPACING**

- Immediately displays the average seed POPULATION and the average seed SPACING of all active rows.
- Each press alternates between seed spacing and seed population.

**AREA FIELD/AREA TOTAL**

- Immediately displays the field or total area planted since the field/total area was last cleared.
- Each press alternates between field area and total area.

**OK**

- Ends and saves the new setup during installation.
- Acknowledges and silences alarms in the operation mode.

**UP ARROW AND DOWN ARROW**

- Scrolls sequentially through the display options on the lower LCD display.
- Freezes on the current row in the scan mode.
- Scrolls sequentially through the rows when the population scan is frozen.
- Used to enter programmable values in the programming mode.
- The UP and DOWN Arrow keys can be pressed at the same time to start the CLEAR function.

**SETUP ENTER/SETUP EXIT**

- Enters and exits the programming mode.

**ON/OFF**

- Powers the unit on and off.

## UPPER LCD FUNCTIONS

(MTR29h)

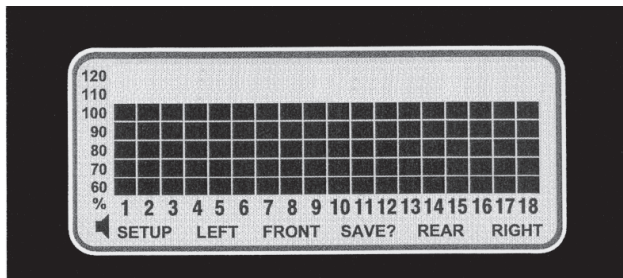

The monitor collects data on the planting rates from all active rows and calculates an average. This average will determine the 100% mark. Seed rate for each row is then compared to the average value and the result is displayed on the bar graph.

With only the KPM II Stack-Mode console programmed into the system, the information regarding each section is displayed alternately every 5 seconds. While operating a system with two sections programmed, one or both sections may be selected any time. When only one section is selected, the monitor calculates the average based on the remaining active rows from that section.

With the SMM console programmed into the system, two sections are viewed at the same time. If the system configuration is for four sections, the display will alternate every 5 seconds between a pair of sections. The select key will lock the display on rear sections. The SMM console shows RIGHT in the left/right configuration, FRONT in the rear/front configuration and FRONT RIGHT/REAR RIGHT in four sections configuration. The KPM II Stack-Mode console shows LEFT in the left/right configuration, REAR in the rear/front configuration and FRONT LEFT/REAR LEFT in four sections configuration.

**STEP 1** Press SELECT key once to show one section. The flashing icon shows the section that is not selected. The selected section icon is continuously displayed on the LCD.

**EXAMPLE:** The system is setup to display rear section on KPM II Stack-Mode console and front section on SMM console. Press SELECT key. The FRONT icon will be flashing and the REAR section will be displayed on the bar graph. The SMM console is only backlit. After 1 minute the front row icon will stop flashing. The monitor will stay in this REAR only display through power down and power up. Each time the monitor is turned on while in REAR only mode, the FRONT icon will flash for 1 minute.

If seed flow is sensed in the FRONT section while planting, the FRONT icon will resume flashing.

When the front section is disabled, the row spacing will automatically double to maintain the proper implement width in the monitor. A 23 or 24 row 15" configuration changes to a 12 row 30" configuration with a touch of the SELECT key.

**STEP 2** Press SELECT key again to activate both sections.

For simple applications, where only one section is programmed, the display will automatically lock on that section. Pressing the SELECT key will have no affect.

**NOTE:** When alternating between two sections, the display will lock on the section containing the first recognized alarm until the alarm is acknowledged by pressing the OK key or the alarm condition is removed.

## LOWER LCD FUNCTIONS

(MTR29g)

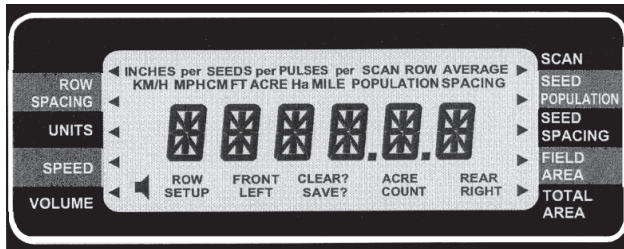

- The UP and DOWN arrow keys will sequentially change what is being displayed on the lower LCD. Pressing the UP or DOWN arrow keys will move the arrow head icon (on the left and right hand side of the display) to another item. For example, if the arrow icon is pointing to SPEED, ground speed will be displayed on the LCD. Pressing the UP arrow key will move the icon to UNITS. The display will change to display all the icons used to represent the current (English or Metric) measurement system.
- The shortcut keys SPEED, SEED POPULATION/SPACING and AREA FIELD/TOTAL allow direct access to their respective displays. For example, no matter what is currently being displayed on the lower LCD, pressing the SPEED key will change the display to the current speed. Pressing the SEED POPULATION/SPACING or AREA FIELD/TOTAL keys will alternate between the two functions assigned to those keys.
- Pressing the SCAN key while displaying seed spacing or population will cause a sequential display of each individual row. Pressing the SCAN key a second time will freeze the display on the currently displayed row. The UP or DOWN arrow keys can be used to change the currently displayed row. Pressing the SCAN key will restart the automatic advancing of the scan function.
- Pressing the SCAN key while displaying speed will cause a sequential display of speed, average planter population and average seed spacing. Pressing the SCAN key a second time will freeze the display on the currently displayed reading.

### ROW SPACING

Press the arrow keys to ROW SPACING to display the current spacing between rows in inches or centimeters. The ROW SPACING icons turn on, displaying a 3 digit, one decimal place format. In the area count mode, this function displays the implement width in feet or meters, using a 3 digit, no decimal places format.

### UNITS

Press the arrow keys to UNITS to display all the icons from the currently selected English or Metric measurement system. For the English system, the icons are: INCH, MPH, FT, ACRE and MILE. For the Metric system, the icons are: M, KM/H and Ha.

### SPEED

Press the SPEED key to display the current speed in MPH or KM/H, using a 3 digit, one decimal place format.

### VOLUME

Press the arrow keys to VOLUME to display the presently selected audible alarm volume. The SPEAKER icon turns on.

### SCAN

Press the SCAN key to display the seed spacing or seed population (see Steps 1-3 following) of each individual row. (1)Pressing the SCAN key while displaying any other function will cause the monitor to sequentially display speed, average seed population and average seed spacing. (2)Pressing the SCAN key a second time will freeze the display. (3)Pressing the SCAN key a third time restarts the sequential display. The UP and DOWN arrow keys can be used to change the current display.

## SEED POPULATION/SEED SPACING

Each SEED POP/SPACING key press alternates between seed population and seed spacing.

Seed population displays the average number of seeds or the row average number of seeds per acre or seeds per hectare for all the active rows. The average is displayed using a 6 digits, no decimal places format. The AVERAGE POPULATION icon will turn on. When in the scan mode, the scan arrow and SCAN ROW POPULATION will appear. The ROW number icon and the current row will be displayed on the left and the population will be displayed on the right in 1000's using 3 digits, one decimal place (e.g. 32.9 means 32,900). When in scan freeze mode, the scan arrow and ROW POPULATION will turn on (scan arrow may be flashing). The UP and DOWN keys may be used to lock on the desired row.

Seed spacing displays the average distance or the row average distance between seeds for all active rows in inches per seed or centimeters per seed using a 3 digit, one decimal place format. When the average is displayed the AVERAGE SPACING icons are turned on. When in the scan mode, the scan arrow and SCAN ROW SPACING icons will appear. The ROW number icon and the current row will be displayed on the left and the spacing will be displayed on the right. The display will sequence to the next row every 5 seconds. When in scan freeze mode, the scan arrow and SPACING will turn on (scan arrow may be flashing). The UP and DOWN keys may be used to lock on the desired row.

## FIELD AREA/TOTAL AREA

Each AREA FIELD/TOTAL key press alternates between field area and total area.

Field area displays the total number of acres or hectares using a 6 digit, one decimal place format.

**NOTE: When FIELD AREA is selected, the UP or DOWN key must be held in slightly longer than normal so the monitor will not mistake this action with a CLEAR, which consists of the UP and DOWN arrow keys pressed simultaneously. A beep will sound when the function activates.**

Total area displays the total number of acres or hectares using a 6 digit, one decimal place format. The total area counter updates every time the field area counter increments. Clearing the total area counter will also clear the field area counter.

When the monitor is programmed as a rear only or rear/front configuration and shaft rotation sensors are installed, pressing the UP arrow to move beyond row spacing lights an arrow on an unlabeled area above ROW SPACING. This is the automatically set division line between the L.H. shaft sensor and the R.H. shaft sensor. The display shows the first row on the rear section and the front section assigned to the R.H. shaft rotation sensor.

**EXAMPLE: On a 12 Row 30" planter with Interplant® Package, the display would appear as follows:**

092597-21

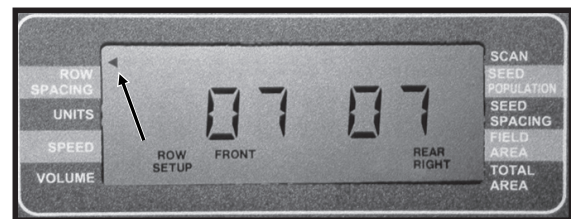

THIS DISPLAY IS NOT ACCESSIBLE ON LEFT/RIGHT CONFIGURATIONS OR SYSTEMS WITHOUT SHAFT ROTATION SENSORS.

PROGRAMMING - Changing The Audible Alarm Volume
---

**STEP 1** To enter the programming mode, press and hold the SETUP key. The monitor will emit several short beeps, followed by a long beep. On the lower LCD, the SETUP icon turns on and the arrow head icon will flash, indicating that the user can select an item to program.

**NOTE: The monitor must be in a programmable function (row spacing, units, speed, volume or area) to enter setup. The monitor will not enter setup in seed population or seed spacing.**

**STEP 2** Press the UP or DOWN arrow keys to move the flashing arrow to VOLUME. As the arrow icon moves, the lower LCD will display the current setting of the item selected.

**STEP 3** Press the OK key and the flashing arrow becomes solid and the audible alarm will sound.

**NOTE: The lower LCD will display the current volume and the SPEAKER icon is turned on. Settings are from 0 to 9.**

- Use the UP or DOWN arrow keys to change the setting. With every UP arrow key push, the alarm will increment by one step between the minimum and the maximum. If the maximum level (9) is reached the volume rolls over to the minimum level (0).
- Pressing the DOWN arrow key lowers the volume until the minimum level (0) is reached, at which point the volume rolls over to the maximum level (9).

**STEP 4** To exit without saving, press and release the OK key. The monitor will restore the lower LCD to show the setting of the item, and the arrow icon will flash, allowing the user to select another item to program.

To exit and save, press and hold the OK key. The monitor will emit several short beeps and SAVE? icon is turned on. After a short time a long beep is heard, and the lower LCD will display the word "DONE". Release the OK key. If the OK key is released BEFORE the word "DONE" is displayed, the changes WILL NOT BE SAVED. The word "DONE" MUST be displayed in order for the save to have occurred.

**NOTE: The programming mode may be exited at any time, by pressing the SETUP key. Pressing this key will return the monitor to its normal operation. All items changed and saved will come into effect immediately. Any items changed, but not saved will revert to the original programmed value.**

## PROGRAMMING - Units (Metric Or English)

**STEP 1** To enter the programming mode, press and hold the SETUP key. The monitor will emit several short beeps, followed by a long beep. On the lower LCD, the SETUP icon turns on and the arrow head icon will flash, indicating that the user can select an item to program.

**NOTE: The monitor must be in a programmable function (row spacing, units, speed, volume or area) to enter setup. The monitor will not enter setup in seed population or seed spacing.**

**STEP 2** Press the UP or DOWN arrow keys to move the flashing arrow to UNITS. As the arrow icon moves, the lower LCD will display the current setting of the item selected.

**STEP 3** Press the OK key and the flashing arrow becomes solid and the audible alarm will sound.

**NOTE: The lower LCD will alternately display all Metric icons or all English icons, indicating the Metric or English mode respectively.**

- Use the UP or DOWN arrow keys to change the setting.

**STEP 4** To exit without saving, press and release the OK key. The monitor will restore the lower LCD to show the setting of the item, and the arrow icon will flash, allowing the user to select another item to program.

To exit and save, press and hold the OK key. The monitor will emit several short beeps and SAVE? icon is turned on. After a short time a long beep is heard, and the lower LCD will display the word "DONE". Release the OK key. If the OK key is released BEFORE the word "DONE" is displayed, the changes WILL NOT BE SAVED. The word "DONE" MUST be displayed in order for the save to have occurred.

**NOTE: The programming mode may be exited at any time, by pressing the SETUP key. Pressing this key will return the monitor to its normal operation. All items changed and saved will come into effect immediately. Any items changed, but not saved will revert to the original programmed value.**

## PROGRAMMING - Row Spacing

**STEP 1** Prior to entering the programming mode, the application mode (rear/front, left/right or four sections) must be active. If the monitor is programmed in a rear/front configuration, both sections will be active (alternating every 5 seconds if the SMM console is not used). You can then set the row spacing to the Interplant® System row spacing.

EXAMPLE: On a 12 Row 30" with Interplant® Package set the row spacing to 15.0 with front active.

When the monitor is in normal field operation mode, disabling the front section will automatically change the row spacing to 30".

**STEP 2** To enter the programming mode, press and hold the SETUP key. The monitor will emit several short beeps, followed by a long beep. On the lower LCD, the SETUP icon turns on and the arrow head icon will flash, indicating that the user can select an item to program.

**NOTE: The monitor must be in a programmable function (row spacing, units, speed, volume or area) to enter setup. The monitor will not enter setup in seed population or seed spacing.**

**STEP 3** Press the UP or DOWN arrow keys to move the flashing arrow to ROW SPACING. As the arrow icon moves, the lower LCD will display the current setting of the item selected.

**STEP 4** Press the OK key and the flashing arrow becomes solid and the audible alarm will sound.

**NOTE: The lower LCD will display the current row spacing (in inches or centimeters) and ROW SPACING icon is turned on.**

- The least significant digit of the displayed value will be blinking.
- This value can be changed by pressing either the UP or DOWN arrow keys.
- Once this digit is correct, press the MODE SELECT key and the blinking digit will move to the next significant digit, where the process can be repeated.

**NOTE:** The monitor limits the entry of row spacing to a minimum of 10.0 inches (25.4 cm) and to a maximum of 99.9 inches (253.7 cm). If the monitor is configured to a rear/front configuration, the limits change to a minimum of 5.0 inches (12.7 cm) and a maximum of 49.9 inches (126.8 cm).

**STEP 5** To exit without saving, press and release the OK key. The monitor will restore the lower LCD to show the setting of the item and the arrow icon will flash, allowing the user to select another item to program.

To exit and save, press and hold the OK key. The monitor will emit several short beeps and SAVE? icon is turned on. After a short time a long beep is heard, and the lower LCD will display the word "DONE". Release the OK key. If the OK key is released BEFORE the word "DONE" is displayed, the changes WILL NOT BE SAVED. The word "DONE" MUST be displayed in order for the save to have occurred.

To exit setup mode, press the SETUP key.

**NOTE:** The programming mode may be exited at any time, by pressing the SETUP key. Pressing this key will return the monitor to its normal operation. All items changed and saved will come into effect immediately. Any items changed, but not saved will revert to the original programmed value.

## PROGRAMMING - Speed

**STEP 1** To enter the programming mode, press and hold the SETUP key. The monitor will emit several short beeps, followed by a long beep. On the lower LCD, the SETUP icon turns on and the arrow head icon will flash, indicating that the user can select an item to program.

**NOTE: The monitor must be in a programmable function (row spacing, units, speed, volume or area) to enter setup. The monitor will not enter setup in seed population or seed spacing.**

**STEP 2** Press the UP or DOWN arrow keys to move the flashing arrow to SPEED. As the arrow icon moves, the lower LCD will display the current setting of the item selected.

**STEP 3** Press the OK key and the flashing arrow becomes solid and the audible alarm will sound. The R.H. digit on the display will be blinking.

The speed constant is used to record how many pulses are generated per mile (or kilometer) from the ground speed sensor. The lower LCD will display the current pulses per mile (or kilometer) using a 6 digit, no decimal place format. The PULSES per MILE (or PULSES per KM) icons are turned on.

**NOTE: It is highly recommended that a field calibration be done to establish the PPM/PPKM (Pulses Per Mile/Kilometer) number on a new machine installation. Several factors can affect this value such as wheel slip on the magnetic distance sensor, mounting angle and height on the radar distance sensor, etc. IT IS NOT UNCOMMON FOR THE SPEED ON THE MONITOR TO VARY SLIGHTLY FROM THE TRACTOR SPEEDOMETER. Adjusting the PPM/PPKM in the monitor to make the speed agree can cause serious errors in acre/hectare counts and population readings. Do field checks to verify populations and seed spacings.**

**NOTE: On new system installations, the monitor will default to 500 PPM (310 PPKM). This will have to be changed to obtain accurate readings from the monitor.**

- In field conditions, measure 330 feet ( $\frac{1}{16}$  mile) or 100 meters, depending on the unit of measurement selected.

- Pull the tractor up to the starting line.

- Press the UP and DOWN arrow keys at the same time and hold them down until the CLEAR? icon is displayed and the monitor beeps several times. When the data is actually cleared, the monitor will emit a long beep and the number of pulses is cleared.

**NOTE: If the PPM/PPKM number starts to count pulses with the tractor not moving, check the radar for vibration or other kinds of interference.**

- Drive the tractor for 330 feet ( $\frac{1}{16}$  mile) or 100 meters and stop.

- The monitor will count the number of pulses and display them.

**STEP 4** To exit without saving, press and release the OK key. The monitor will restore the lower LCD to show the previous setting of the item, and the arrow icon will flash, allowing the user to select another item to program.

To exit and save, press and hold the OK key. The monitor will emit several short beeps and SAVE? icon is turned on. After a short time a long beep is heard, and the lower LCD will display the word "DONE". Release the OK key. If the OK key is released BEFORE the word "DONE" is displayed, the changes WILL NOT BE SAVED. The word "DONE" MUST be displayed in order for the save to have occurred.

**NOTE: The programming mode may be exited at any time, by pressing the SETUP key. Pressing this key will return the monitor to its normal operation. All items changed and saved will come into effect immediately. Any items changed, but not saved will revert to the original programmed value.**

NOTE: If a discrepancy occurs and digits must be changed, follow STEPS 1 and 2 to enter the programming mode and proceed as follows:

- Press the OK key and the flashing arrow becomes solid. The least significant digit of the displayed value will be blinking.
- This value can be changed by pressing either the UP or DOWN arrow keys.
- Once this digit is correct, press the SELECT key and the blinking digit will move to the next significant digit, where the process can be repeated.

The monitor limits the entry of pulses per mile or kilometer to a minimum of 500 PPM (310 PPKM), and to a maximum of 500,000 PPM (310,686 PPKM).

KEY Action	Flashing Digit	Display Value
Press The UP Key	Right Most Digit	2031, 2032, 2033
Press The SELECT Key	Second Digit From Right	2033
Press The DOWN Key	Second Digit From Right	2023, 2013, 2003, 2093, 2083
Press The SELECT Key Twice	Left Most Digit	2083
Press The DOWN Key	Left Most Digit	1083, 0500 (Min. Value), 9500, 8500

## PROGRAMMING - Clearing Total Area

**NOTE: Clearing the total area counter will also clear the field area counter.**

**STEP 1** To enter the programming mode, press and hold the SETUP key. The monitor will emit several short beeps followed by a long beep. On the lower LCD, the SETUP icon turns on and the arrow head icon will flash, indicating that the user can select an item to program.

**NOTE: The monitor must be in a programmable function (row spacing, units, speed, volume or area) to enter setup. The monitor will not enter setup in seed population or seed spacing.**

**STEP 2** Press the UP or DOWN arrow keys to move the flashing arrow to TOTAL AREA. As the arrow icon moves, the lower LCD will display the current setting of the item selected.

**STEP 3** Press the OK key and the flashing arrow becomes solid and the audible alarm will sound.

- The lower LCD will display the total area and the ACRE (or Ha) icon turns on.
- With the flashing arrow on TOTAL AREA, press the OK key.

• To reset the counter, press the UP and DOWN arrow keys at the same time and hold them down for a short period of time to clear the data. The CLEAR? icon will be displayed and the monitor will beep several times. When the data is actually cleared, the monitor will emit a long beep, and the total area is reset to zeros. After the long beep, the previous recorded total area is not retrievable. Once cleared, the user **may not** choose to exit programming mode without saving as described in STEP 4.

**STEP 4** To exit and save, press and hold the OK key. The monitor will emit several short beeps and SAVE? icon is turned on. After a short time a long beep is heard, and the lower LCD will display the word "DONE". Release the OK key. If the OK key is released BEFORE the word "DONE" is displayed, the changes WILL NOT BE SAVED. The word "DONE" MUST be displayed in order for the save to have occurred.

**NOTE: The programming mode may be exited at any time, by pressing the SETUP key. Pressing this key will return the monitor to its normal operation. All items changed and saved will come into effect immediately. Any items changed, but not saved will revert to the original programmed value.**

## AREA COUNTER/SPEEDOMETER MODE

If the monitor is installed with only a radar distance sensor (no seed tubes attached), the monitor becomes a speedometer. If (a) the monitor is connected to a radar distance sensor, (b) the signal cable from the back of the console is connected to a sensing switch (Part No. G1K249 Acre Counter Switch Kit) instead of the seed tubes and (c) the implement width in feet (or meters) is programmed into the monitor, the monitor will function as an area counter.

The seed spacing and seed population functions are not available in this mode. If the monitor is powered down, the seed tubes connected and the monitor powered up, the monitor will again show seed population and seed spacing in inches or centimeters. Row spacing reverts back to its programmed setting.

## WARNINGS AND ALARMS

- 1. System Alarms** - A system alarm is activated when the monitor detects a faulty sensor or one of several other communication faults.

The corresponding row number starts flashing and the audible alarm sounds. All segments on the corresponding bar graph are turned off. Pushing the OK key to acknowledge the warning will turn the alarm off. The row number will continue to flash until the alarm condition is removed. If the monitor detects a faulty sensor and there is no planting activity present, the monitor will scroll "CHECK CONNECTION".

If the distance sensor is detected as faulty, the monitor will display either "PICKUP" or "RADAR", depending on the type of sensor installed, and the audible alarm will sound. The user can push the OK key to acknowledge the alarm. When the distance sensor is faulty, the monitor will change to a bar graph only mode where the rows are still displayed relative to each other. No area related information (speed, field area, total area, seed spacing or seed population) will be accumulated or displayed.

If a rotation shaft sensor is faulty, "LSHAFT" or "RSHAFT" will display. On Model 3800 planters, "SHAFT1", "SHAFT2", "SHAFT3" or "SHAFT4" will display.

Another type of system alarm occurs when the monitor detects a data communication bus error.

The four possible data communication bus errors are:

LCD Display	Error Condition
SYS HI	The data communication lead (green) has been shorted to the power lead (white).
SYS LO	The data communication lead (green) has been shorted to the ground lead (black).
SYS EC	An internal error has been detected.
COP	Cycled power ON/OFF to quickly.

- 2. Under Flow Alarms** - If the seed rate for one or more rows is less than 55% of the calculated average, the corresponding 60% segment will stay on, the corresponding row number starts flashing and the alarm sounds. Pushing the OK key to acknowledge the warning will turn the alarm off. The 60% segment of the bar graph remains on and the row number continues to flash until the alarm condition is corrected.

**NOTE: All alarms present within a short time before planting stops are frozen on the screen and the text LOW or FAIL will display on the LCD. If the under flow is between 0% and 10%, this warrants a "FAIL" condition. If the under flow is between 10% and 55%, a "LOW" condition is generated. If multiple rows have an under flow condition, "FAIL" will display if any one or more rows is between 0% and 10%. This allows the user to identify and fix the problem rows.**

**NOTE: This warning will not trigger unless a minimum time of continuous planting has passed.**

**NOTE: If all the rows show a seed rate of zero, the condition will not generate an alarm. It will be assumed the planter has stopped. The row numbers and the bottom 60% segment will remain on for all selected rows.**

- 3. Multiple Alarms** - If more than one alarm condition occurs at the same time, pushing the OK key will acknowledge all alarms that are currently displayed. For example, if one row on the front and one row on the rear are alarming, pushing the OK key will only acknowledge one of them. However, if there are two alarms on the front, both alarms would be acknowledged with one push of the OK key.

4. **Section Not Selected Warning** - If the monitor was programmed for two sections and only one is currently selected for display (by pressing the SELECT key), the icon of the disabled section will flash for a period of 1 minute, then turn off at each power up. If seed flow is sensed in the disabled section, the icon for that section (front, left or right) will begin to flash.
5. **Seed Planting Stopped Warning** - When the monitor detects no seed flow on all rows, the monitor will emit 3 short beeps to alert the user. This warning will occur each time the planter is stopped, each time the planter is raised at the end of a row or if the mechanical drive fails while planting.

**NOTE: This warning will not trigger unless a minimum time of continuous planting has passed.**

6. **Seed Counting Sensor In Calibration Warning** - All seed counting sensors run a self-calibration sequence on power up. While in calibration the bottom segment of each corresponding bar graph will flash if the monitor detects movement or planting activity. If the monitor does not detect this, the message "WAIT CALIBRATION" will be scrolled.
7. **Seed Counting Sensor Too Dirty Warning** - After the seed counting sensors end their internal self-calibration, the monitor may detect one or more sensors are either too dirty or blocked. If the monitor detects planting or movement, the corresponding bar graph remains flashing. The monitor will display "CLEAN SENSORS" on the top LCD if no movement or planting is detected, prompting the user to clean the tubes. If the tubes are dirty, they will still show seed flow with less accuracy. If the tubes are blocked the user will get an alarm as soon as planting starts. The corresponding bar graph will remain flashing until the problem is corrected and the monitor is powered down and then powered back up.
8. **Low Battery Warning** - The monitor is constantly monitoring its input voltage to quickly detect low power conditions. If the monitor detects that the input voltage has dropped below 11.0V, it will display "LO SYS" on the lower LCD on the KPM II Stack-Mode console, provided that the monitor does not detect speed or planting.

**NOTE: After the alarms have been acknowledged and if the alarm condition is still present, the LCD will continue to display the alarm condition.**

#### REPLACING A FAULTY SENSOR

**NOTE: Stack-Mode Seed Sensors are identified by a blue 3-pin connector. Replace Stack-Mode Seed Sensors with like components only.**

To replace a faulty sensor; (a) disconnect the faulty sensor and check the monitor to be sure the correct sensor was disconnected, (b) turn the monitor off, (c) after a few seconds, turn the monitor back on and (d) plug in the replacement sensor. The monitor will chirp twice to acknowledge the new sensor was learned and saved.

To replace more than one faulty sensor, proceed as stated above for rear/front or left/right configurations beginning with the lowest numbered row in the rear or left section and continue to replace sensors in ascending order. Then move on to the front or right section and continue in ascending order. For four section configurations, begin with rear/left and continue to rear/right, then front/left and ending with front/right.

If the monitor detects a faulty distance sensor, the lower LCD will immediately move to the speed display, show the word "PICKUP" or "RADAR" depending on the distance sensor installed, and the alarm will sound.

**NOTE: If the monitor is not turned off and then on, the replacement sensor(s) will be ignored until the next power on, at which point the sensors will be randomly learned by the monitor.**

## FIELD OPERATION

Press the ON/OFF key to turn the monitor on.



(MTR28e)

Information regarding each section is displayed alternately every 5 seconds.

### REAR/FRONT CONFIGURATION (Without SMM Console Installed)

- Press the SELECT key once to show REAR section only. (Monitor sets correct row spacing.)
- Press the SELECT key a second time to return to each section being displayed alternately every 5 seconds on KPM II Stack-Mode console. (Monitor sets correct row spacing.)
- Press the SELECT key a third time to show REAR section only again.



(MTR28c)

### REAR/FRONT CONFIGURATION (With SMM Console Installed)

- Press the SELECT key once to show REAR section only on KPM II Stack-Mode console. (Monitor sets correct row spacing.)
- Press the SELECT key a second time to show FRONT section on SMM console and REAR section on KPM II Stack-Mode console. (Monitor sets correct row spacing.)
- Press the SELECT key a third time to show REAR section only again.



(MTR28c)

### FOUR SECTION CONFIGURATION (With SMM Console Installed)

- Press the SELECT key once to show REAR and LEFT sections on KPM II Stack-Mode console and REAR and RIGHT sections on SMM console. (Monitor sets correct row spacing.)
- Press the SELECT key a second time to return to all four sections, alternating right front and right rear on SMM console and alternating left front and left rear on KPM II Stack-Mode console. (Monitor sets correct row spacing.)
- Press the SELECT key a third time to show REAR and LEFT sections on KPM II Stack-Mode console and REAR and RIGHT sections on SMM console again.



(MTR28c)

**NOTE: SELECT key has no function when only a single section is being used.**

At power up, the lower LCD will show speed (MPH or KM/H).

(MTR29g/MTR29b/MTR29a/MTR29c/MTR29f/MTR29c/MTR29f)

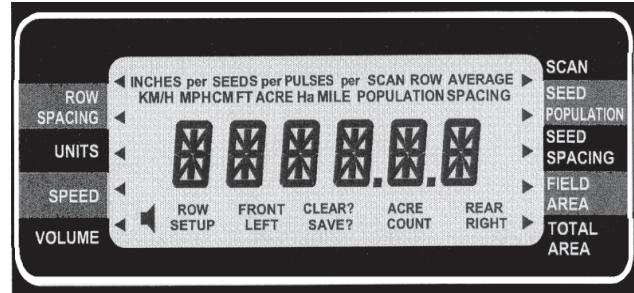

Press the UP or DOWN arrow keys to move the flashing arrow on the lower LCD to change what is displayed on the lower LCD.



Press the shortcut keys SPEED, SEED POPULATION/SEED SPACING or AREA FIELD/TOTAL for direct access to these displays.



(MTR29c/MTR29d/MTR29b/MTR29c)

Press the SEED POPULATION/SEED SPACING or AREA FIELD/TOTAL keys to alternate between the two functions assigned to that key.



Press the SEED POPULATION/SEED SPACING key to choose average seed spacing/population per acre.



Press the SCAN key to display individual rows starting at row 1.



Press the SCAN key again to lock on current row.

Press the SCAN key again to resume scrolling.

Use the UP or DOWN arrow keys to move to a particular row.



Press the SEED POPULATION/SEED SPACING key to go back to planter average.



## CLEARING FIELD AREA

(MTR29n/MTR28b)

To reset the counter, press the UP or DOWN arrow keys to move the arrow in the lower display to FIELD AREA.



Press the UP and DOWN arrow keys at the same time and hold them down for a short period of time to clear the data. The CLEAR? icon will be displayed and the monitor will beep several times. When the data is actually cleared, the monitor will emit a long beep, and the field area is reset to zero. After the long beep, the previous field area recorded is not retrievable.



**NOTE: Clearing the field area counter will not clear the total area counter. See “Programming-Clearing Total Area” for clearing total area.**

Press the OK key to silence alarms. See “Warnings And Alarms”.



**PROGRAMMING/CONNECTING SMM CONSOLE, SHAFT ROTATION SENSORS, SEED TUBES AND/OR RADAR/MAGNETIC DISTANCE SENSORS**

**STEP 1** All sensors (including the seed tubes w/ sensors, radar, magnetic distance, SMM console and shaft rotation sensors) must be unplugged from the harness and/or console and the monitor must be off.

**NOTE:** If the monitor detects a radar sensor but no seed tubes at power up, it will automatically go into AREA COUNT mode. See “Area Counter/Speedometer Mode”.

**NOTE:** Disconnect magnetic distance sensor between MDS adapter and planter harness. DO NOT disconnect between MDS and MDS adapter.

01189909

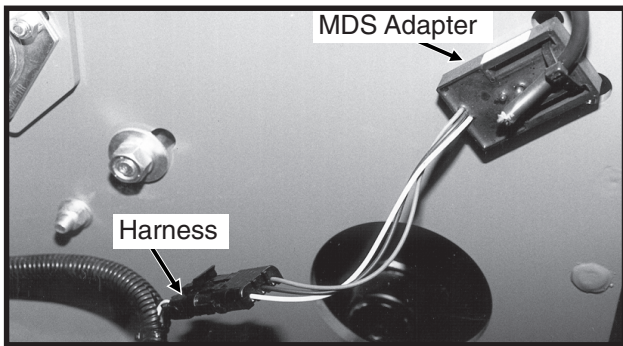

01189910

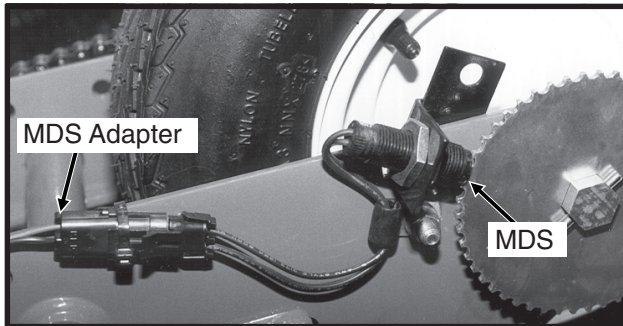

**STEP 2** Press the ON key. The monitor automatically enters the setup procedure. Monitor will scroll “NO SENSOR” on top LCD of KPM II Stack-Mode console.

**STEP 3** The monitor automatically defaults to rear/front. Press the SELECT key once for left/right and twice for four sections (front right/front left/rear right/rear left). The selected display will be solid and the configuration not currently selected will be flashing.

12060211

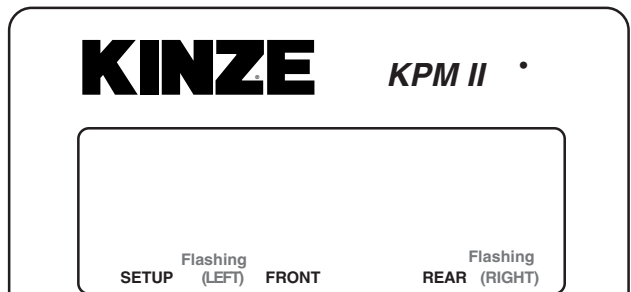

ROW	SETUP	SCAN
UNITS		SEED
SPEED		SEED
VOLUME		FIELD
		TOTAL

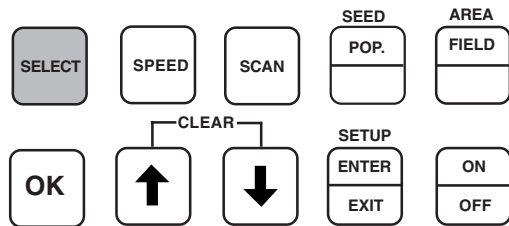

**NOTE:** SMM console may not be applicable to all models.

12060211

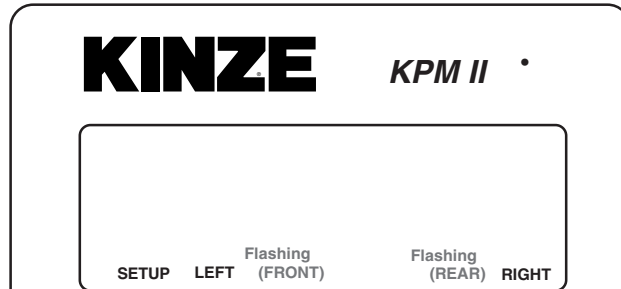

ROW	SETUP	SCAN
UNITS		SEED
SPEED		FIELD
VOLUME		TOTAL

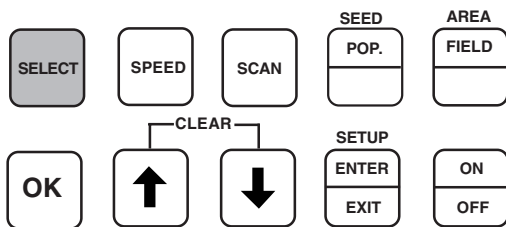

**NOTE: SMM console may not be applicable to all models.**

**NOTE: Model 3000, 3110, 3120, 3140, 3200, 3400, 3500, 3600, 3650 and 3700 (16 row) planters select the rear/front configuration. Model 3700 (24/36 row) and Model 3800 planters select left/right configuration.**

**STEP 4** Press and hold the OK key to confirm selection. The upper display will alternate between “NEW” and “SYS?”.

The alarm will sound four short beeps followed by one long beep. At this point your selection has been saved and row numbers will appear flashing on the upper display of the KPM II.

12060211

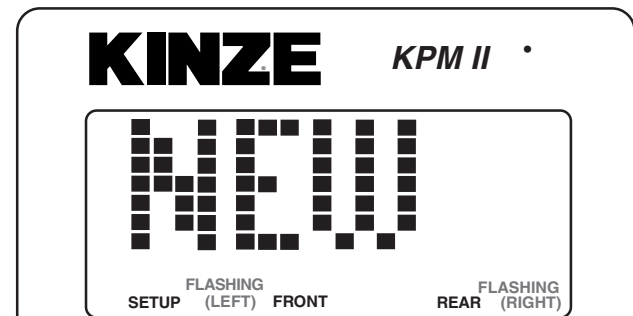

ROW SPACING	SETUP	SCAN
UNITS		SEED POPULATION
SPEED		SEED SPACING
VOLUME		FIELD AREA
		TOTAL AREA

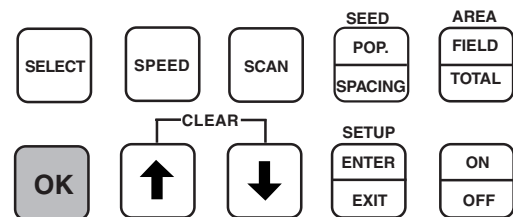

**NOTE: SMM console may not be applicable to all models.**

**NOTE: Illustrated using rear/front configuration.**  
 The KPM II Stack-Mode console shows LEFT in the left/right configuration, REAR in the rear/front configuration and FRONT LEFT/REAR LEFT in the four sections configuration.

**STEP 5** (If Applicable) Connect SMM console into junction Y-harness which was installed between the KPM II Stack-Mode console and the primary harness. The SMM console will show a lighted screen and KPM will show on the lower LCD.

12060211



12060211

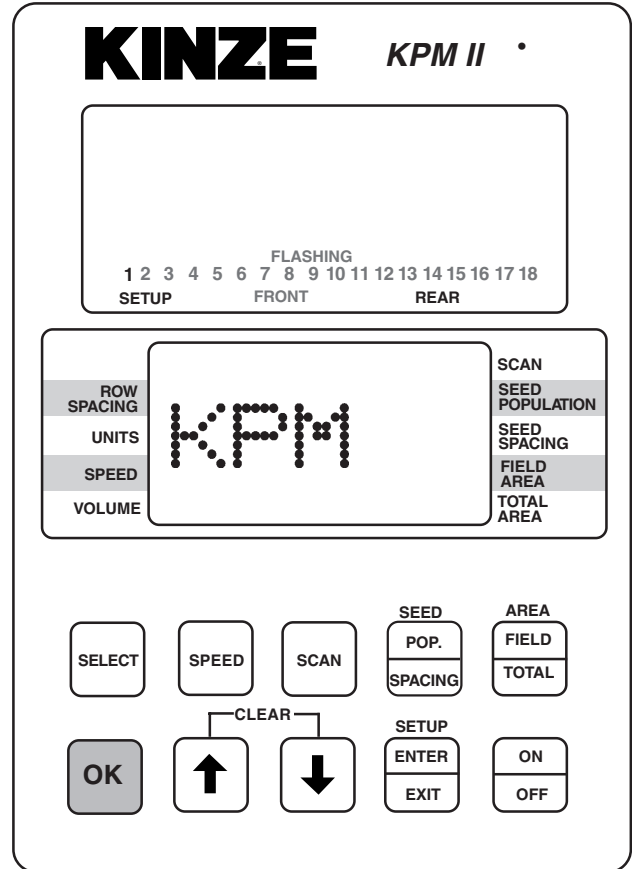
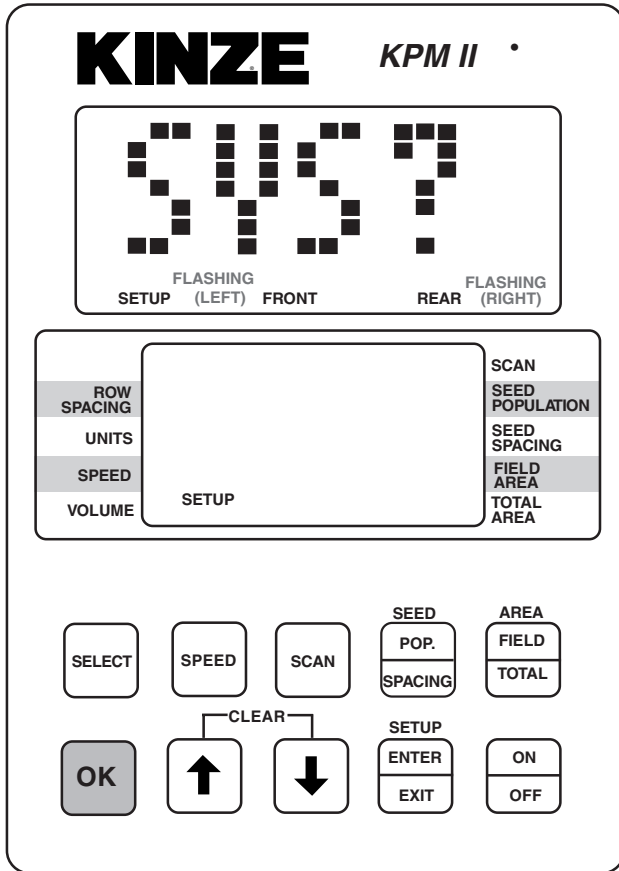

**NOTE: SMM console may not be applicable to all models.**

**NOTE: SMM console may not be applicable to all models.**

**STEP 6** If the monitor system includes shaft rotation sensors, these should be installed at this time. Plug in the L.H. shaft first, then the R.H. shaft. L.H. and R.H. is determined by facing in the direction the machine will travel when in use.

01189906

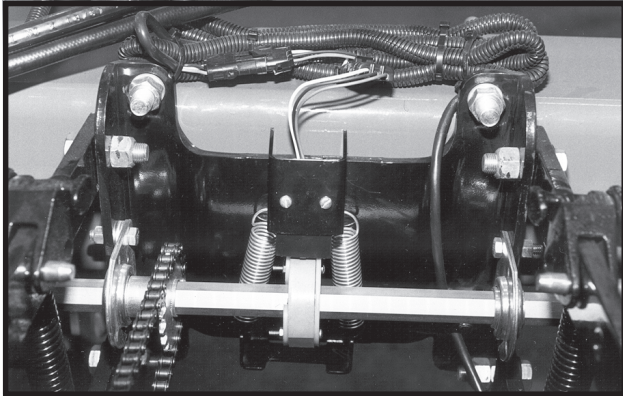

“LSHAFT” or “SHAFT 1” will display on the lower LCD when the first shaft rotation sensor is installed. “RSHAFT” or “SHAFT 2” will display when the second shaft rotation sensor is installed.

**NOTE: Illustrated using rear/front configuration. The KPM II Stack-Mode console shows LEFT in the left/right configuration, REAR in the rear/front configuration and FRONT LEFT/REAR LEFT in the four sections configuration.**

**MODEL 3800 PLANTERS** - The first shaft rotation sensor installed will be assigned to the rows on the outer L.H. half of the planter and the second shaft rotation sensor connected will be assigned to the rows on the inner L.H. half of the planter.

“SHAFT 1” will display on the lower LCD when the first shaft rotation sensor is installed. “SHAFT 2” will display when the second shaft rotation sensor is installed. “SHAFT 3” will display on the lower LCD when the third shaft rotation sensor is installed on the inner R.H. half of the planter. “SHAFT 4” will display when the fourth shaft rotation sensor is installed on the outer R.H. half of the planter.

12060211

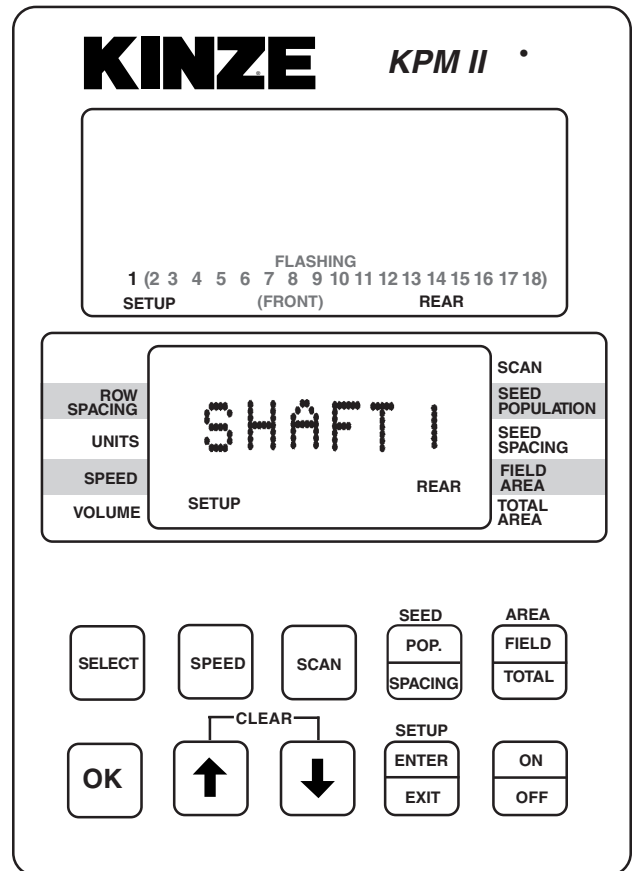

**NOTE: SMM console may not be applicable to all models.**

## STEP 6 (Continued)

12060211

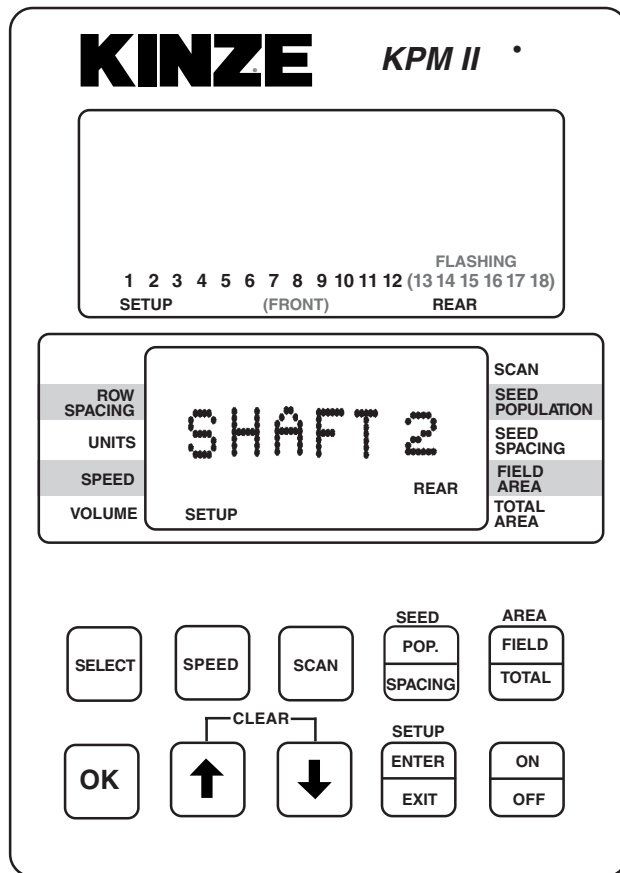

**NOTE: SMM console may not be applicable to all models.**

## STEP 7 Determine which row you want as number one and plug the seed tube w/sensor into the harness.

Continue plugging in sensors along with shaft rotation sensors if so equipped. Row 1 first, row 2 second and so on up to 18 rows. When a sensor is plugged in, the corresponding row number on the upper LCD display will stay solid, the monitor will chirp twice and a red LED (Light Emitting Diode) on the seed tube sensor will turn on for approximately 30 seconds to show connection is made.

(METR55b)

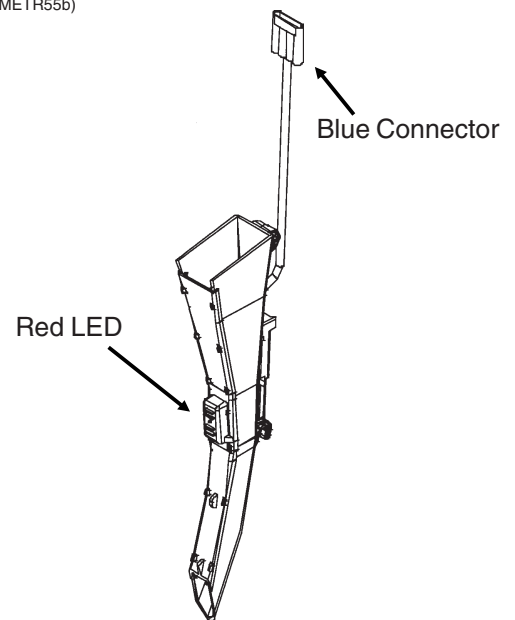

**NOTE: Illustrated using rear/front configuration. The KPM II Stack-Mode console shows LEFT in the left/right configuration, REAR in the rear/front configuration and REAR LEFT/FRONT LEFT in the four sections configuration.**

## STEP 7 (Continued)

12060211

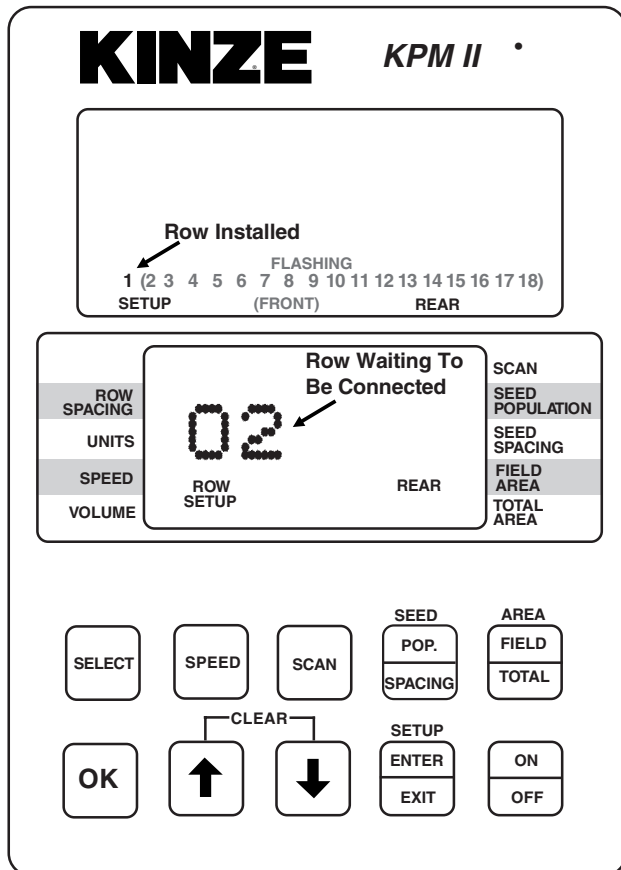

**NOTE: SMM console may not be applicable to all models.**

**STEP 8** When all the seed tubes for the current section (rear/front, left/right or four section) are installed, check to be sure the upper LCD on the KPM II Stack-Mode console displays solid numbers for the number of seed tubes connected. Press and hold the OK key to save the setup for the current section. The SAVE? icon will display followed by continuous short beeps indicating the monitor is preparing to save. The installer has 5 seconds to decide to save the current configuration. During this time, four short beeps will sound followed by a long beep and the SAVE? icon will turn off and the word "DONE" shows on the screen. The monitor will continue to the second section installation (If Applicable).

**NOTE: Illustrated using rear/front configuration. The KPM II Stack-Mode console shows LEFT in the left/right configuration, REAR in the rear/front configuration and FRONT LEFT/REAR LEFT in the four sections configuration.**

12060211

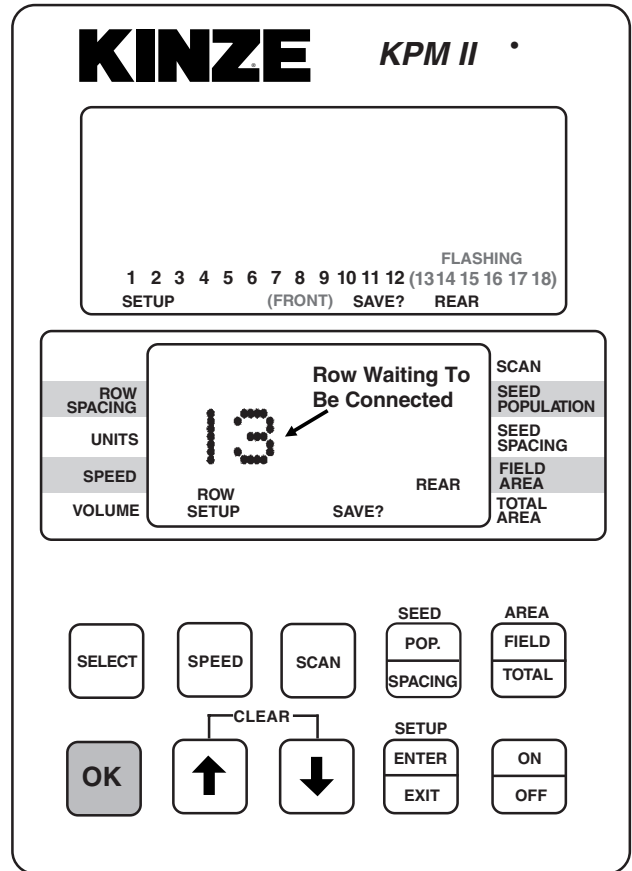

**NOTE: SMM console may not be applicable to all models.**

## STEP 8 (Continued)

12060211

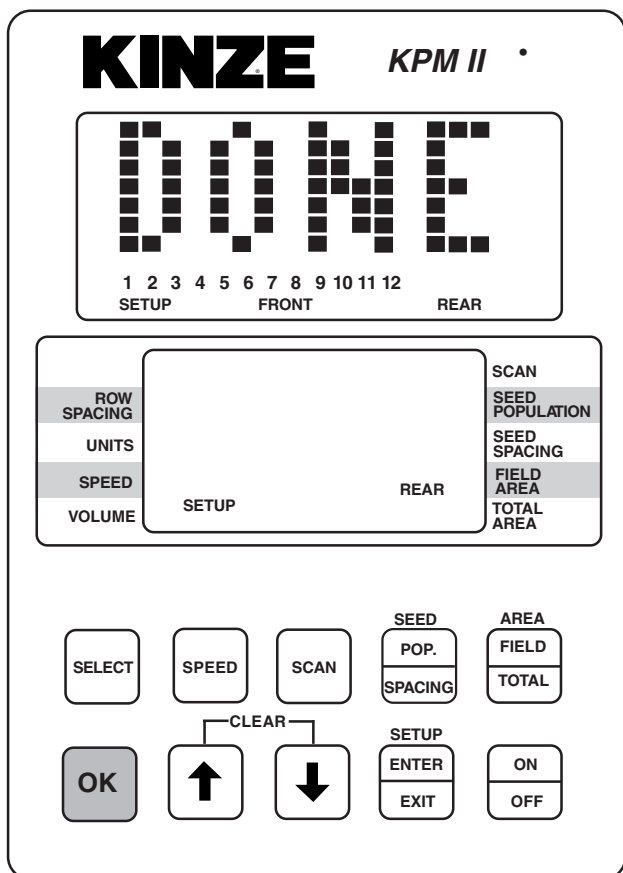

**NOTE: SMM console may not be applicable to all models.**

**STEP 9** Follow STEPS 6, 7 and 8 to install the second, third and fourth sections. If no seed tubes are installed on additional sections, press and hold the OK key. The word "DONE" will appear on upper display. The alarm will sound four short beeps followed by one long beep and the SAVE? icon turns off. The monitor has exited the setup mode. When you release the OK key the upper display will scroll "WAITING CALIBRATION". The lower display will show "GNDSPD" and the alarm will sound continually until the distance sensor is connected. See STEP 10.

**NOTE:** The SMM console LCD remains blank (except the backlighted screen) until the entire system is saved.

**NOTE:** Illustrated using rear/front configuration. The KPM II Stack-Mode console shows LEFT in the left/right configuration, REAR in the rear/front configuration and FRONT LEFT/REAR LEFT in the four sections configuration. The SMM console shows RIGHT in the left/right configuration, FRONT in the front/rear configuration and FRONT RIGHT/REAR RIGHT in four sections configuration.

12060212

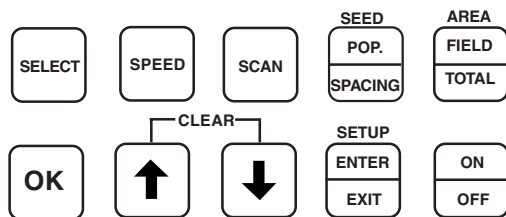
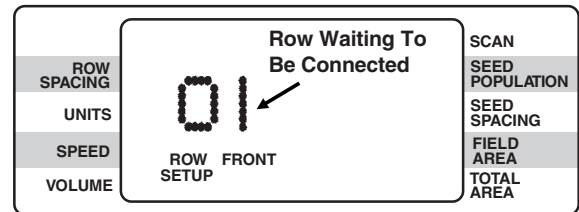
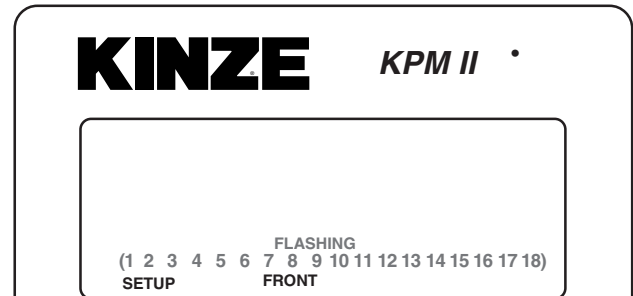
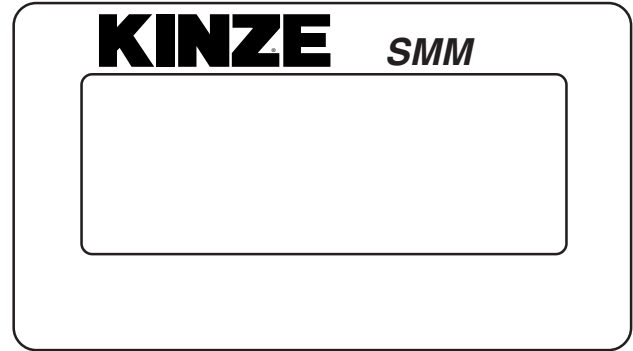

**NOTE:** SMM console may not be applicable to all models.

**STEP 9** (Continued)

12060213



12060214

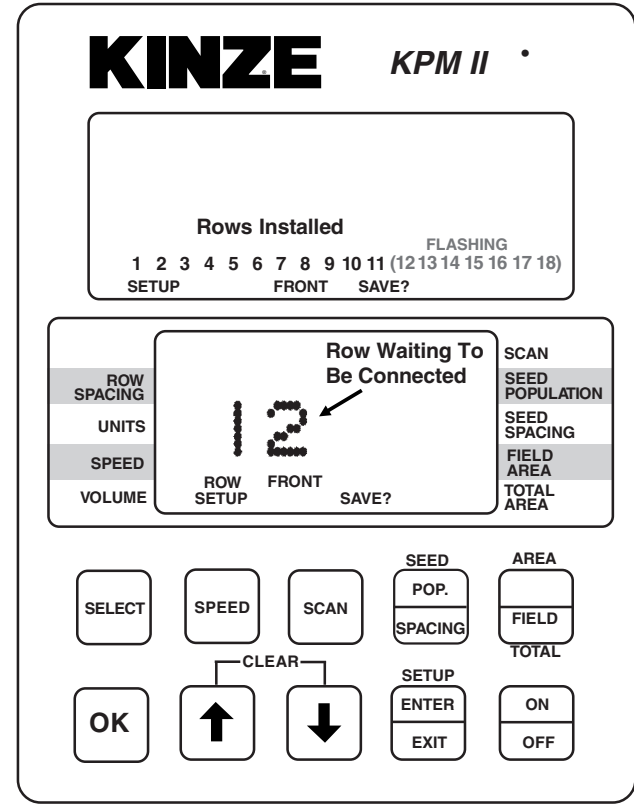
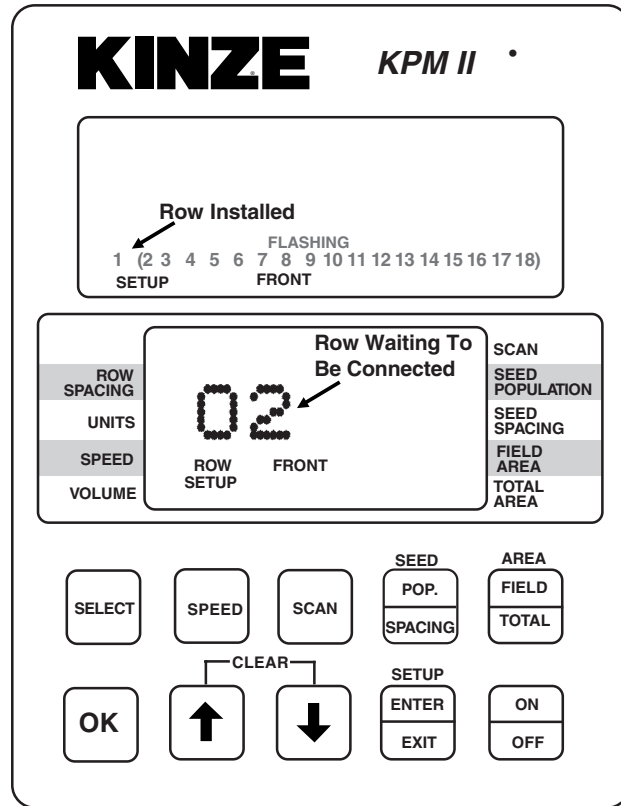

**NOTE:** SMM console may not be applicable to all models.

**NOTE:** SMM console may not be applicable to all models.

**STEP 9** (Continued)

12060215

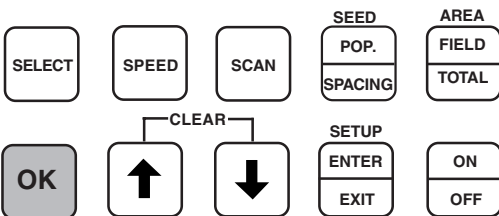
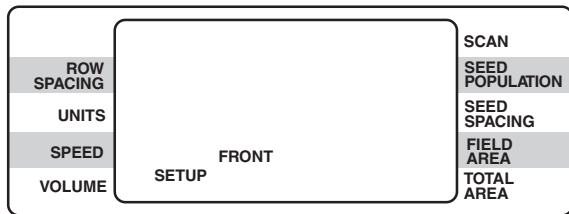
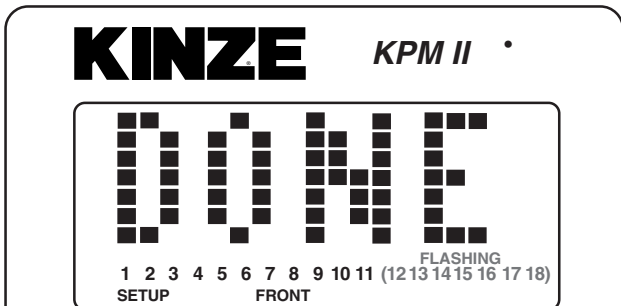

**NOTE: SMM console may not be applicable to all models.**

**STEP 10** With the lower display showing “GNDSPD”, connect the distance sensor. The monitor will display “PICKUP” if a magnetic distance sensor is connected or “RADAR” if a radar distance sensor is installed. Only one distance sensor can be connected at a time.

**NOTE: Illustrated using rear/front configuration.** The KPM II Stack-Mode console shows LEFT in the left/right configuration, REAR in the rear/front configuration and FRONT LEFT/REAR LEFT in the four sections configuration. The SMM console shows RIGHT in the left/right configuration, FRONT in the rear/front configuration and FRONT RIGHT/REAR RIGHT in four sections configuration.

**NOTE: To connect the radar distance sensor, install the 10" monitor/radar adapter between the console and radar distance sensor to adapt the monitor system to various tractor radar systems. DO NOT CONNECT 10" MONITOR/RADAR ADAPTER PRIOR TO THIS STEP.**

## STEP 10 (Continued)

12060216

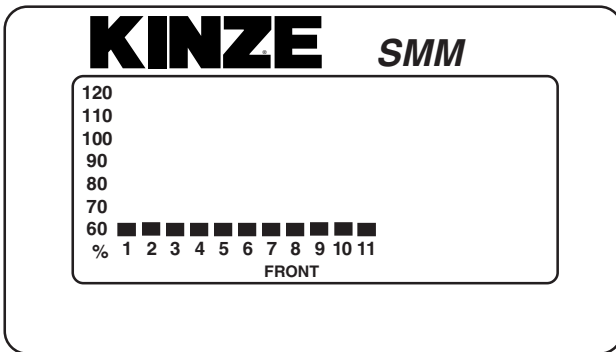

**KINZE KPM II**

120
110
100
90
80
70
60
% 1 2 3 4 5 6 7 8 9 10 11 12
REAR

ROW SPACING	GNDSPD	SCAN
UNITS		SEED POPULATION
SPEED		SEED SPACING
VOLUME		FIELD AREA
		TOTAL AREA
	REAR	

SELECT	SPEED	SCAN	SEED POP. SPACING	AREA FIELD TOTAL
OK	CLEAR		SETUP ENTER EXIT	ON OFF
	↑	↓		

**NOTE: SMM console may not be applicable to all models.**

**NOTE: To reprogram the system to monitor more or less rows (up to the maximum of 18 per section, 72 total in four section configuration), all sensors must be unplugged, followed by the complete setup procedure.**

**NOTE: Individual seed tubes may be unplugged for special situations. An alarm will sound which can be silenced by touching the OK key. The monitor will recognize the seed tube(s) when reconnected.**

12060217

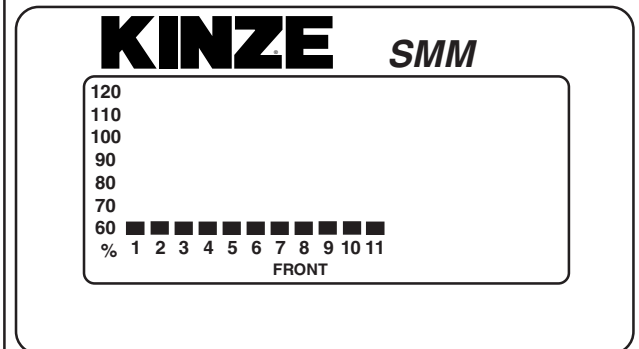

**KINZE KPM II**

120
110
100
90
80
70
60
% 1 2 3 4 5 6 7 8 9 10 11 12
REAR

ROW SPACING	MPH	SCAN
UNITS		SEED POPULATION
SPEED		SEED SPACING
VOLUME		FIELD AREA
		TOTAL AREA

SELECT	SPEED	SCAN	SEED POP. SPACING	AREA FIELD TOTAL
OK	CLEAR		SETUP ENTER EXIT	ON OFF
	↑	↓		

**NOTE: SMM console may not be applicable to all models.**

**ROW-BY-ROW ALARM LEVEL SETTING**  
*(Requires Version V2.05 Or Higher Software -  
 KPM II Stack-Mode Monitors Only)*

This feature allows the audio alarm to be disabled on selected rows in applications such as planting seed corn.

**NOTE:** The system should be programmed to monitor all planter rows prior to performing these steps.

**NOTE:** Illustrated using rear/front configuration. The KPM II Stack-Mode console shows LEFT in the left/right configuration, REAR in the rear/front configuration and FRONT LEFT/REAR LEFT in the four sections configuration. The SMM console shows RIGHT in the left/right configuration, FRONT in the rear/front configuration and FRONT RIGHT/REAR RIGHT in four sections configuration.

**STEP 1** Enter the programming mode by pressing and holding the SETUP key. The monitor will emit several short beeps, followed by a long beep. On the lower LCD, the SETUP icon will turn on and the arrow head icon will flash, indicating the user can select an item to program.

**NOTE:** The monitor must be in a programmable function (row spacing, unit, speed, volume or area) to enter setup. The monitor will not enter setup in seed population or seed spacing.

**STEP 2** Press the UP or DOWN arrow keys to move the flashing arrow to SEED POPULATION. As the arrow icon moves, the lower LCD will display the current setting of each item selected.

12060218

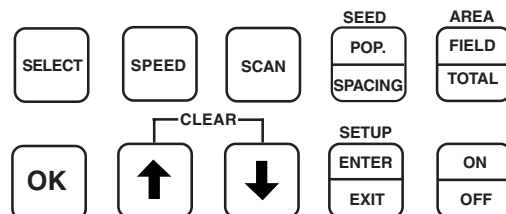
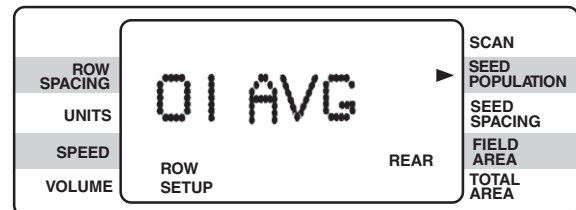
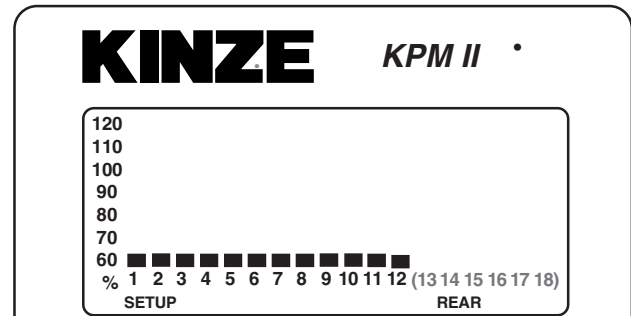
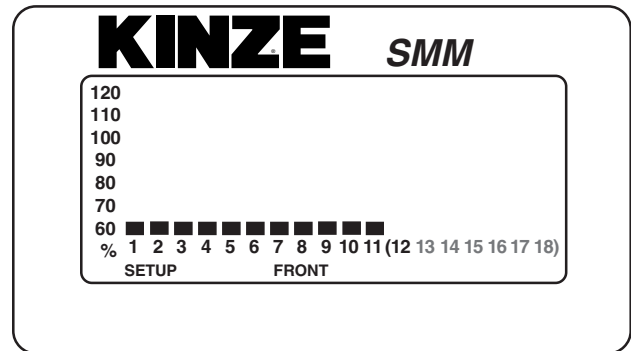

**NOTE:** SMM console may not be applicable to all models.

**STEP 3** Press the OK key. Row number starts flashing.

**STEP 4** Arrow UP or DOWN to desired row.

**STEP 5** Press SELECT key. "AVG" starts flashing.

**STEP 6** Arrow UP or DOWN to choose one of the following options.

HIGH - For Early Alarm (70%)  
AVG - For Standard Alarm Setting (55%)  
LOW - For Failed Alarm Only (25%)  
OFF - To Disable Row Alarm

**STEP 7** Press and hold the OK key to save alarm setting. There will be four short beeps, one long beep and the word "DONE" will appear when the save is completed.

**STEP 8** Repeat STEPS 3 through 7 for each row on which you wish to adjust the alarm setting.

**STEP 9** When finished, press the SETUP key to exit setup mode.

**NOTE: The programming mode may be exited at any time by pressing the SETUP key. Pressing this key will return the monitor to its normal operation. All items changed and saved will come into effect immediately. Any items changed, but not saved will revert to the original programmed value.**

**NOTE: Repeat STEPS 3 through 7 to change seed monitor back to the original settings when special row-by-row alarm level settings are no longer required.**

**NOTE:**  
**See "Programming - Row Spacing" for programming applicable row spacing.**

# CONTENTS LISTINGS

IS628

<b>MODEL 3000 Pull Type (Mechanical Seed Metering)</b>	<b>4 Row</b>	<b>6 Row</b>	<b>8 Row</b>
KPM I Monitor Package	700-05088	700-05089	700-05090
KPM II Stack-Mode Monitor Package Magnetic Distance Sensor	700-05091	700-05092	700-05093
KPM II Stack-Mode Monitor Package Radar Distance Sensor	700-05094	700-05095	700-05096
Interplant® Monitor Package	700-05114	700-05115	700-05116

<b>MODEL 3110 3 Pt. Mounted Rigid Frame (Mechanical Seed Metering)</b>	<b>6 Row</b>	<b>8 Row</b>
KPM I Monitor Package	700-05089	700-05090
KPM II Stack-Mode Monitor Package Magnetic Distance Sensor	700-05092	700-05093
KPM II Stack-Mode Monitor Package Radar Distance Sensor	700-05095	700-05096

<b>MODEL 3120 3 Pt. Mounted Vertical Folding (Mechanical Seed Metering)</b>	<b>8 Row</b>	<b>12 Row</b>
KPM I Monitor Package	700-05090	700-05108
KPM II Stack-Mode Monitor Package Magnetic Distance Sensor	700-05120	700-05121
KPM II Stack-Mode Monitor Package Radar Distance Sensor	700-05119	700-05122

<b>MODEL 3140 3 Pt. Mounted Stack Folding (Mechanical Seed Metering)</b>	<b>8 Row</b>	<b>12 Row</b>	<b>16 Row</b>
KPM I Monitor Package	700-05097	700-05098	700-05099
KPM II Stack-Mode Monitor Package Magnetic Distance Sensor	700-05100	700-05101	700-05102
KPM II Stack-Mode Monitor Package Radar Distance Sensor	700-05103	700-05104	700-05105

# CONTENTS LISTINGS

IS628

<b>MODEL 3200 Flex Econo-Fold® (Mechanical Seed Metering)</b>	<b>8 Row</b>	<b>12 Row</b>
KPM I Monitor Package	700-05090	700-05108
KPM II Stack-Mode Monitor Package Magnetic Distance Sensor	700-05124	700-05110
KPM II Stack-Mode Monitor Package Radar Distance Sensor	700-05119	700-05122

<b>MODEL 3400 Twin-Line® (Mechanical Seed Metering)</b>	<b>12 Row</b>
KPM I Monitor Package	700-05108
KPM II Stack-Mode Monitor Package Magnetic Distance Sensor	700-05130
KPM II Stack-Mode Monitor Package Radar Distance Sensor	700-05131
Interplant® Monitor Package	700-05117

<b>MODEL 3500 Twin-Line® (Mechanical Seed Metering)</b>	<b>6 Row</b>	<b>8 Row</b>
KPM I Monitor Package	700-05089	700-05090
KPM II Stack-Mode Monitor Package Magnetic Distance Sensor	700-05092	700-05093
KPM II Stack-Mode Monitor Package Radar Distance Sensor	700-05095	700-05096
Interplant® Monitor Package	700-05115	700-05116

# CONTENTS LISTINGS

IS628

<b>MODEL 3600 Twin-Line® (Mechanical Seed Metering)</b>	<b>8 Row</b>	<b>12 Row</b>	<b>16 Row</b>
KPM I Monitor Package	700-05090	700-05108	700-05109
KPM II Stack-Mode Monitor Package Magnetic Distance Sensor	700-05124	700-05110	700-05111
KPM II Stack-Mode Monitor Package Radar Distance Sensor	700-05119	700-05112	700-05113
Interplant® Monitor Package	700-05116	700-05117	700-05118

<b>MODEL 3650 Twin-Line® (Mechanical Seed Metering)</b>	<b>12 Row</b>	<b>16 Row</b>
KPM I Monitor Package	700-05108	700-05109
KPM II Stack-Mode Monitor Package Magnetic Distance Sensor	700-05110	700-05111
KPM II Stack-Mode Monitor Package Radar Distance Sensor	700-05112	700-05113
Interplant® Monitor Package	700-05117	700-05118

<b>MODEL 3700 Front Folding (Mechanical Seed Metering)</b>	<b>16 Row</b>	<b>24 Row</b>	<b>36 Row</b>
KPM I Monitor Package	700-05125	700-05128	700-05129
KPM II Stack-Mode Monitor Package Magnetic Distance Sensor	700-05126	700-05132	700-05134
KPM II Stack-Mode Monitor Package Radar Distance Sensor	700-05127	700-05133	700-05135

<b>MODEL 3800 Forward Folding (Mechanical Seed Metering)</b>	<b>24 Row</b>	<b>32 Row</b>	<b>36 Row</b>
KPM II Stack-Mode Monitor Package Magnetic Distance Sensor	700-05136	700-05138	700-05140
KPM II Stack-Mode Monitor Package Radar Distance Sensor	700-05137	700-05139	700-05141

<b>MODEL 3000 Pull Type (EdgeVac® Seed Metering)</b>	<b>4 Row</b>	<b>6 Row</b>	<b>8 Row</b>
KPM I Monitor Package	700-05209	700-05210	700-05211
KPM II Stack-Mode Monitor Package Magnetic Distance Sensor	700-05212	700-05213	700-05214
KPM II Stack-Mode Monitor Package Radar Distance Sensor	700-05215	700-05216	700-05217
Interplant® Monitor Package	700-05252	700-05253	700-05254

<b>MODEL 3110 3 Pt. Mounted Rigid Frame (EdgeVac® Seed Metering)</b>	<b>6 Row</b>	<b>8 Row</b>
KPM I Monitor Package	700-05210	700-05211
KPM II Stack-Mode Monitor Package Magnetic Distance Sensor	700-05213	700-05214
KPM II Stack-Mode Monitor Package Radar Distance Sensor	700-05216	700-05217

<b>MODEL 3140 3 Pt. Mounted Stack Folding (EdgeVac® Seed Metering)</b>	<b>8 Row</b>	<b>12 Row</b>	<b>16 Row</b>
KPM I Monitor Package	700-05218	700-05219	700-05220
KPM II Stack-Mode Monitor Package Magnetic Distance Sensor	700-05221	700-05222	700-05223
KPM II Stack-Mode Monitor Package Radar Distance Sensor	700-05224	700-05225	700-05226

<b>MODEL 3200 Flex Econo-Fold® (EdgeVac® Seed Metering)</b>	<b>8 Row</b>	<b>12 Row</b>
KPM I Monitor Package	700-05211	700-05227
KPM II Stack-Mode Monitor Package Magnetic Distance Sensor	700-05234	700-05229
KPM II Stack-Mode Monitor Package Radar Distance Sensor	700-05233	700-05231

<b>MODEL 3400 Twin-Line® (EdgeVac® Seed Metering)</b>	<b>12 Row</b>
KPM I Monitor Package	700-05227
KPM II Stack-Mode Monitor Package Magnetic Distance Sensor	700-05244
KPM II Stack-Mode Monitor Package Radar Distance Sensor	700-05245
Interplant® Monitor Package	700-05255

<b>MODEL 3500 Twin-Line® (EdgeVac® Seed Metering)</b>	<b>6 Row</b>	<b>8 Row</b>
KPM I Monitor Package	700-05210	700-05211
KPM II Stack-Mode Monitor Package Magnetic Distance Sensor	700-05213	700-05214
KPM II Stack-Mode Monitor Package Radar Distance Sensor	700-05216	700-05217
Interplant® Monitor Package	700-05253	700-05254

<b>MODEL 3600 Twin-Line® (EdgeVac® Seed Metering)</b>	<b>8 Row</b>	<b>12 Row</b>	<b>16 Row</b>
KPM I Monitor Package	700-05211	700-05227	700-05228
KPM II Stack-Mode Monitor Package Magnetic Distance Sensor	700-05234	700-05229	700-05230
KPM II Stack-Mode Monitor Package Radar Distance Sensor	700-05233	700-05231	700-05232
Interplant® Monitor Package	700-05254	700-05255	700-05256

<b>MODEL 3650 Twin-Line® (EdgeVac® Seed Metering)</b>	<b>12 Row</b>	<b>16 Row</b>
KPM I Monitor Package	700-05227	700-05228
KPM II Stack-Mode Monitor Package Magnetic Distance Sensor	700-05229	700-05230
KPM II Stack-Mode Monitor Package Radar Distance Sensor	700-05231	700-05232
Interplant® Monitor Package	700-05255	700-05256

<b>MODEL 3700 Front Folding (EdgeVac® Seed Metering)</b>	<b>16 Row</b>	<b>24 Row</b>	<b>36 Row</b>
KPM I Monitor Package	700-05235	700-05236	700-05237
KPM II Stack-Mode Monitor Package Magnetic Distance Sensor	700-05238	700-05239	700-05240
KPM II Stack-Mode Monitor Package Radar Distance Sensor	700-05241	700-05242	700-05243

<b>MODEL 3800 Forward Folding (EdgeVac® Seed Metering)</b>	<b>24 Row</b>	<b>32 Row</b>	<b>36 Row</b>
KPM II Stack-Mode Monitor Package Magnetic Distance Sensor	700-05246	700-05248	700-05250
KPM II Stack-Mode Monitor Package Radar Distance Sensor	700-05247	700-05249	700-05251

## 4 ROW SIZES (Mechanical Seed Metering)

### KPM I Monitor Package, 4 Row - 700-05088

#### Model 3000

- (1)IS628 Instructions
- (1)IS448 Quick Reference Guide
- (1)A10570 Backlit Console W/Fuse (1-36 Row)
- (1)A8021 Planter Harness W/Dust Caps (4 Row)
- (1)A8143 50 Pc. Pkg. (D1512) Tie Straps
- (4)A10901 Seed Tube W/Sensor

### KPM II Monitor Package, 4 Row - 700-05091 (With Magnetic Distance Sensor)

#### Model 3000

- (1)IS628 Instructions
- (1)IS539 Quick Reference Guide
- (1)A10575 Backlit Console W/Fuse (1-36 Row)
- (1)A8021 Planter Harness W/Dust Caps (4 Row)
- (4)A10901 Seed Tube W/Sensor
- (1)A6147 Sensor And Mounting Package
- (1)A7859 MDS Adapter
- (1)A8143 50 Pc. Pkg. (D1512) Tie Straps

### KPM II Monitor Package, 4 Row - 700-05094 (With Radar Distance Sensor)

#### Model 3000

- (1)IS628 Instructions
- (1)IS539 Quick Reference Guide
- (1)A10575 Backlit Console W/Fuse (1-36 Row)
- (1)A8021 Planter Harness W/Dust Caps (4 Row)
- (4)A10901 Seed Tube W/Sensor
- (1)A7858 Radar Sensor
- (1)A8026 Radar Pipe/Mounting Bracket Package
- (1)A8143 50 Pc. Pkg. (D1512) Tie Straps

## 4 ROW SIZES (EdgeVac® Seed Metering)

### KPM I Monitor Package, 4 Row - 700-05209

#### Model 3000

- (1)IS628 Instructions
- (1)IS448 Quick Reference Guide
- (1)A10570 Backlit Console W/Fuse (1-36 Row)
- (1)A8021 Planter Harness W/Dust Caps (4 Row)
- (1)A8143 50 Pc. Pkg. (D1512) Tie Straps
- (4)A10142 Seed Tube W/Sensor

### KPM II Monitor Package, 4 Row - 700-05212 (With Magnetic Distance Sensor)

#### Model 3000

- (1)IS628 Instructions
- (1)IS539 Quick Reference Guide
- (1)A10575 Backlit Console W/Fuse (1-36 Row)
- (1)A8021 Planter Harness W/Dust Caps (4 Row)
- (4)A10142 Seed Tube W/Sensor
- (1)A6147 Sensor And Mounting Package
- (1)A7859 MDS Adapter
- (1)A8143 50 Pc. Pkg. (D1512) Tie Straps

### KPM II Monitor Package, 4 Row - 700-05215 (With Radar Distance Sensor)

#### Model 3000

- (1)IS628 Instructions
- (1)IS539 Quick Reference Guide
- (1)A10575 Backlit Console W/Fuse (1-36 Row)
- (1)A8021 Planter Harness W/Dust Caps (4 Row)
- (4)A10142 Seed Tube W/Sensor
- (1)A7858 Radar Sensor
- (1)A8026 Radar Pipe/Mounting Bracket Package
- (1)A8143 50 Pc. Pkg. (D1512) Tie Straps

6 ROW SIZES (Mechanical Seed Metering)	6 ROW SIZES (EdgeVac® Seed Metering)
<p><b>KPM I Monitor Package, 6 Row - 700-05089</b>  <b><u>Models 3000, 3110 Rigid Frame And 3500</u></b>            (1)IS628 Instructions            (1)IS448 Quick Reference Guide            (1)A10570 Backlit Console W/Fuse (1-36 Row)            (1)A8022 Planter Harness W/Dust Caps (6 Row)            (6)A10901 Seed Tube W/Sensor            (1)A8143 50 Pc. Pkg. (D1512) Tie Straps</p> <p><b>KPM II Monitor Package, 6 Row - 700-05092</b>  <b>(With Magnetic Distance Sensor)</b>  <b><u>Models 3000, 3110 Rigid Frame And 3500</u></b>            (1)IS628 Instructions            (1)IS539 Quick Reference Guide            (1)A10575 Backlit Console W/Fuse (1-36 Row)            (1)A8022 Planter Harness W/Dust Caps (6 Row)            (6)A10901 Seed Tube W/Sensor            (1)A6147 Sensor And Mounting Package            (1)A7859 MDS Adapter            (1)A8143 50 Pc. Pkg. (D1512) Tie Straps</p> <p><b>KPM II Monitor Package, 6 Row - 700-05095</b>  <b>(With Radar Distance Sensor)</b>  <b><u>Models 3000, 3110 Rigid Frame And 3500</u></b>            (1)IS628 Instructions            (1)IS539 Quick Reference Guide            (1)A10575 Backlit Console W/Fuse (1-36 Row)            (1)A8022 Planter Harness W/Dust Caps (6 Row)            (6)A10901 Seed Tube W/Sensor            (1)A7858 Radar Sensor            (1)A8026 Radar Pipe/Mounting Bracket Package            (1)A8143 50 Pc. Pkg. (D1512) Tie Straps</p>	<p><b>KPM I Monitor Package, 6 Row - 700-05210</b>  <b><u>Models 3000, 3110 Rigid Frame And 3500</u></b>            (1)IS628 Instructions            (1)IS448 Quick Reference Guide            (1)A10570 Backlit Console W/Fuse (1-36 Row)            (1)A8022 Planter Harness W/Dust Caps (6 Row)            (6)A10142 Seed Tube W/Sensor            (1)A8143 50 Pc. Pkg. (D1512) Tie Straps</p> <p><b>KPM II Monitor Package, 6 Row - 700-05213</b>  <b>(With Magnetic Distance Sensor)</b>  <b><u>Models 3000, 3110 Rigid Frame And 3500</u></b>            (1)IS628 Instructions            (1)IS539 Quick Reference Guide            (1)A10575 Backlit Console W/Fuse (1-36 Row)            (1)A8022 Planter Harness W/Dust Caps (6 Row)            (6)A10142 Seed Tube W/Sensor            (1)A6147 Sensor And Mounting Package            (1)A7859 MDS Adapter            (1)A8143 50 Pc. Pkg. (D1512) Tie Straps</p> <p><b>KPM II Monitor Package, 6 Row - 700-05216</b>  <b>(With Radar Distance Sensor)</b>  <b><u>Models 3000, 3110 Rigid Frame And 3500</u></b>            (1)IS628 Instructions            (1)IS539 Quick Reference Guide            (1)A10575 Backlit Console W/Fuse (1-36 Row)            (1)A8022 Planter Harness W/Dust Caps (6 Row)            (6)A10142 Seed Tube W/Sensor            (1)A7858 Radar Sensor            (1)A8026 Radar Pipe/Mounting Bracket Package            (1)A8143 50 Pc. Pkg. (D1512) Tie Straps</p>

## **8 ROW SIZES (Mechanical Seed Metering)**

### **KPM I Monitor Package, 8 Row - 700-05090**

#### **Models 3000, 3110 Rigid Frame, 3120 Vertical Folding, 3200, 3500 And 3600**

- (1)IS628 Instructions
- (1)IS448 Quick Reference Guide
- (1A10570 Backlit Console W/Fuse (1-36 Row)
- (1)A7850 Planter Harness W/Dust Caps (8 Row)
- (8)A10901 Seed Tube W/Sensor
- (1)A8143 50 Pc. Pkg. (D1512) Tie Straps

### **KPM I Monitor Package, 8 Row - 700-05097**

#### **Model 3140 Stack Folding**

- (1)IS628 Instructions
- (1)IS448 Quick Reference Guide
- (1)A10570 Backlit Console W/Fuse (1-36 Row)
- (2)A7849 Extension Harness W/Female Connectors, 15'
- (1)A8022 Planter Harness W/Dust Caps (6 Row)
- (2)A8021 Planter Harness W/Dust Caps (4 Row)
- (8)A10901 Seed Tube W/Sensor
- (1)A8143 50 Pc. Pkg. (D1512) Tie Straps

### **KPM II Monitor Package, 8 Row - 700-05120 (With Magnetic Distance Sensor)**

#### **Model 3120 Vertical Folding**

- (1)IS628 Instructions
- (1)IS539 Quick Reference Guide
- (1)A10575 Backlit Console W/Fuse (1-36 Row)
- (1)A7850 Planter Harness W/Dust Caps (8 Row)
- (8)A10901 Seed Tube W/Sensor
- (1)A5606 Sensor And Mounting Package
- (1)A7859 MDS Adapter
- (1)A8128 Drill Shaft Sensor Mounting Kit
- (1)A8135 Drill Shaft Rotation Sensor Kit
- (1)A8143 50 Pc. Pkg. (D1512) Tie Straps

### **KPM II Monitor Package, 8 Row - 700-05124 (With Magnetic Distance Sensor)**

#### **Models 3200 And 3600**

- (1)IS628 Instructions
- (1)IS539 Quick Reference Guide
- (1)A10575 Backlit Console W/Fuse (1-36 Row)
- (1)A7850 Planter Harness W/Dust Caps (8 Row)
- (8)A10901 Seed Tube W/Sensor
- (1)A6147 Sensor And Mounting Package
- (1)A7859 MDS Adapter
- (1)A8128 Drill Shaft Sensor Mounting Kit
- (1)A8135 Drill Shaft Rotation Sensor Kit
- (1)A8143 50 Pc. Pkg. (D1512) Tie Straps

### **KPM II Monitor Package, 8 Row - 700-05093 (With Magnetic Distance Sensor)**

#### **Models 3000, 3110 Rigid Frame And 3500**

- (1)IS628 Instructions
- (1)IS539 Quick Reference Guide
- (1)A10575 Backlit Console W/Fuse (1-36 Row)
- (1)A7850 Planter Harness W/Dust Caps (8 Row)
- (8)A10901 Seed Tube W/Sensor
- (1)A6147 Sensor And Mounting Package
- (1)A7859 MDS Adapter
- (1)A8143 50 Pc. Pkg. (D1512) Tie Straps

### **KPM II Monitor Package, 8 Row - 700-05100 (With Magnetic Distance Sensor)**

#### **Model 3140 Stack Folding**

- (1)IS628 Instructions
- (1)IS539 Quick Reference Guide
- (1)A10575 Backlit Console W/Fuse (1-36 Row)
- (2)A7849 Extension Harness W/Female Connectors, 15'
- (1)A8022 Planter Harness W/Dust Caps (6 Row)
- (2)A8021 Planter Harness W/Dust Caps (4 Row)
- (8)A10901 Seed Tube W/Sensor
- (1)A6147 Sensor And Mounting Package
- (1)A7859 MDS Adapter
- (1)A8128 Drill Shaft Sensor Mounting Kit
- (1)A8135 Drill Shaft Rotation Sensor Kit
- (1)A8143 50 Pc. Pkg. (D1512) Tie Straps

### **KPM II Monitor Package, 8 Row - 700-05119 (With Radar Distance Sensor)**

#### **Models 3120 Vertical Folding, 3200 And 3600**

- (1)IS628 Instructions
- (1)IS539 Quick Reference Guide
- (1)A10575 Backlit Console W/Fuse (1-36 Row)
- (1)A7850 Planter Harness W/Dust Caps (8 Row)
- (8)A10901 Seed Tube W/Sensor
- (1)A7858 Radar Sensor
- (1)A8128 Drill Shaft Sensor Mounting Kit
- (1)A8135 Drill Shaft Rotation Sensor Kit
- (1)A8026 Radar Pipe/Mounting Bracket Package
- (1)A8143 50 Pc. Pkg. (D1512) Tie Straps

**KPM II Monitor Package, 8 Row - 700-05096  
(With Radar Distance Sensor)**

**Model 3110 Rigid Frame And 3500**

- (1)IS628 Instructions
- (1)IS539 Quick Reference Guide
- (1)A10575 Backlit Console W/Fuse (1-36 Row)
- (1)A7850 Planter Harness W/Dust Caps (8 Row)
- (8)A10901 Seed Tube W/Sensor
- (1)A7858 Radar Sensor
- (1)A8026 Radar Pipe/Mounting Bracket Package
- (1)A8143 50 Pc. Pkg. (D1512) Tie Straps

**KPM II Monitor Package, 8 Row - 700-05103  
(With Radar Distance Sensor)**

**Model 3140 Stack Folding**

- (1)IS628 Instructions
- (1)IS539 Quick Reference Guide
- (1)A10575 Backlit Console W/Fuse (1-36 Row)
- (2)A7849 Extension Harness W/Female Connectors, 15'
- (1)A8022 Planter Harness W/Dust Caps (6 Row)
- (2)A8021 Planter Harness W/Dust Caps (4 Row)
- (8)A10901 Seed Tube W/Sensor
- (1)A7858 Radar Sensor
- (1)A8128 Drill Shaft Sensor Mounting Kit
- (1)A8135 Drill Shaft Rotation Sensor Kit
- (1)A8026 Radar Pipe/Mounting Bracket Package
- (1)A8143 50 Pc. Pkg. (D1512) Tie Straps

**8 ROW SIZES (EdgeVac® Seed Metering)**

**KPM I Monitor Package, 8 Row - 700-05211**

**Models 3000, 3110 Rigid Frame, 3200, 3500 And 3600**

- (1)IS628 Instructions
- (1)IS448 Quick Reference Guide
- (1)A10570 Backlit Console W/Fuse (1-36 Row)
- (1)A7850 Planter Harness W/Dust Caps (8 Row)
- (8)A10142 Seed Tube W/Sensor
- (1)A8143 50 Pc. Pkg. (D1512) Tie Straps

**KPM I Monitor Package, 8 Row - 700-05218**

**Model 3140 Stack Folding**

- (1)IS628 Instructions
- (1)IS448 Quick Reference Guide
- (1)A10570 Backlit Console W/Fuse (1-36 Row)
- (2)A7849 Extension Harness W/Female Connectors, 15'
- (1)A8022 Planter Harness W/Dust Caps (6 Row)
- (2)A8021 Planter Harness W/Dust Caps (4 Row)
- (8)A10142 Seed Tube W/Sensor
- (1)A8143 50 Pc. Pkg. (D1512) Tie Straps

**KPM II Monitor Package, 8 Row - 700-05234  
(With Magnetic Distance Sensor)**

**Models 3200 And 3600**

- (1)IS628 Instructions
- (1)IS539 Quick Reference Guide
- (1)A10575 Backlit Console W/Fuse (1-36 Row)
- (1)A7850 Planter Harness W/Dust Caps (8 Row)
- (8)A10142 Seed Tube W/Sensor
- (1)A6147 Sensor And Mounting Package
- (1)A7859 MDS Adapter
- (1)A8128 Drill Shaft Sensor Mounting Kit
- (1)A8135 Drill Shaft Rotation Sensor Kit
- (1)A8143 50 Pc. Pkg. (D1512) Tie Straps

**KPM II Monitor Package, 8 Row - 700-05214  
(With Magnetic Distance Sensor)**

**Models 3000, 3110 Rigid Frame And 3500**

- (1)IS628 Instructions
- (1)IS539 Quick Reference Guide
- (1)A10575 Backlit Console W/Fuse (1-36 Row)
- (1)A7850 Planter Harness W/Dust Caps (8 Row)
- (8)A10142 Seed Tube W/Sensor
- (1)A6147 Sensor And Mounting Package
- (1)A7859 MDS Adapter
- (1)A8143 50 Pc. Pkg. (D1512) Tie Straps

**KPM II Monitor Package, 8 Row - 700-05221  
(With Magnetic Distance Sensor)**

**Model 3140 Stack Folding**

- (1)IS628 Instructions
- (1)IS539 Quick Reference Guide
- (1)A10575 Backlit Console W/Fuse (1-36 Row)
- (2)A7849 Extension Harness W/Female Connectors, 15'
- (1)A8022 Planter Harness W/Dust Caps (6 Row)
- (2)A8021 Planter Harness W/Dust Caps (4 Row)
- (8)A10142 Seed Tube W/Sensor
- (1)A6147 Sensor And Mounting Package
- (1)A7859 MDS Adapter
- (1)A8128 Drill Shaft Sensor Mounting Kit
- (1)A8135 Drill Shaft Rotation Sensor Kit
- (1)A8143 50 Pc. Pkg. (D1512) Tie Straps

**KPM II Monitor Package, 8 Row - 700-05233  
(With Radar Distance Sensor)**

**Models 3200 And 3600**

- (1)IS628 Instructions
- (1)IS539 Quick Reference Guide
- (1)A10575 Backlit Console W/Fuse (1-36 Row)
- (1)A7850 Planter Harness W/Dust Caps (8 Row)
- (8)A10142 Seed Tube W/Sensor
- (1)A7858 Radar Sensor
- (1)A8128 Drill Shaft Sensor Mounting Kit
- (1)A8135 Drill Shaft Rotation Sensor Kit
- (1)A8026 Radar Pipe/Mounting Bracket Package
- (1)A8143 50 Pc. Pkg. (D1512) Tie Straps

**KPM II Monitor Package, 8 Row - 700-05217  
(With Radar Distance Sensor)**

**Model 3110 Rigid Frame And 3500**

- (1)IS628 Instructions
- (1)IS539 Quick Reference Guide
- (1)A10575 Backlit Console W/Fuse (1-36 Row)
- (1)A7850 Planter Harness W/Dust Caps (8 Row)
- (8)A10142 Seed Tube W/Sensor
- (1)A7858 Radar Sensor
- (1)A8026 Radar Pipe/Mounting Bracket Package
- (1)A8143 50 Pc. Pkg. (D1512) Tie Straps

**KPM II Monitor Package, 8 Row - 700-05224  
(With Radar Distance Sensor)**

**Model 3140 Stack Folding**

- (1)IS628 Instructions
- (1)IS539 Quick Reference Guide
- (1)A10575 Backlit Console W/Fuse (1-36 Row)
- (2)A7849 Extension Harness W/Female Connectors, 15'
- (1)A8022 Planter Harness W/Dust Caps (6 Row)
- (2)A8021 Planter Harness W/Dust Caps (4 Row)
- (8)A10142 Seed Tube W/Sensor
- (1)A7858 Radar Sensor
- (1)A8128 Drill Shaft Sensor Mounting Kit
- (1)A8135 Drill Shaft Rotation Sensor Kit
- (1)A8026 Radar Pipe/Mounting Bracket Package
- (1)A8143 50 Pc. Pkg. (D1512) Tie Straps

## 12 ROW SIZES (Mechanical Seed Metering)

### KPM I Monitor Package, 12 Row - 700-05098

#### Model 3140 Stack Folding

- (1)IS628 Instructions
- (1)IS448 Quick Reference Guide
- (1)A10570 Backlit Console W/Fuse (1-36 Row)
- (2)A7849 Extension Harness W/Female Connectors, 15'
- (1)A7850 Planter Harness W/Dust Caps (8 Row)
- (2)A8021 Planter Harness W/Dust Caps (4 Row)
- (12)A10901 Seed Tube W/Sensor
- (2)A8143 50 Pc. Pkg. (D1512) Tie Straps

### KPM I Monitor Package, 12 Row - 700-05108

#### Models 3120 Vertical Folding, 3200, 3400, 3600 And 3650

- (1)IS628 Instructions
- (1)IS448 Quick Reference Guide
- (1)A10570 Backlit Console W/Fuse (1-36 Row)
- (1)A7851 Planter Harness W/Dust Caps (12 Row)
- (12)A10901 Seed Tube W/Sensor
- (2)A8143 50 Pc. Pkg. (D1512) Tie Straps

### KPM II Monitor Package, 12 Row - 700-05121 (With Magnetic Distance Sensor)

#### Model 3120 Vertical Folding

- (1)IS628 Instructions
- (1)IS539 Quick Reference Guide
- (1)A10575 Backlit Console W/Fuse (1-36 Row)
- (1)A7851 Planter Harness W/Dust Caps (12 Row)
- (12)A10901 Seed Tube W/Sensor
- (1)A5606 Sensor And Mounting Package
- (1)A7859 MDS Adapter
- (1)A8128 Drill Shaft Sensor Mounting Kit
- (1)A8135 Drill Shaft Rotation Sensor Kit
- (2)A8143 50 Pc. Pkg. (D1512) Tie Straps

### KPM II Monitor Package, 12 Row - 700-05110 (With Magnetic Distance Sensor)

#### Models 3200, 3600 And 3650

- (1)IS628 Instructions
- (1)IS539 Quick Reference Guide
- (1)A10575 Backlit Console W/Fuse (1-36 Row)
- (1)A7851 Planter Harness W/Dust Caps (12 Row)
- (12)A10901 Seed Tube W/Sensor
- (1)A6147 Sensor And Mounting Package
- (1)A7859 MDS Adapter
- (1)A8128 Drill Shaft Sensor Mounting Kit
- (1)A8135 Drill Shaft Rotation Sensor Kit
- (2)A8143 50 Pc. Pkg. (D1512) Tie Straps

### KPM II Monitor Package, 12 Row - 700-05130 (With Magnetic Distance Sensor)

#### Model 3400

- (1)IS628 Instructions
- (1)IS539 Quick Reference Guide
- (1)A10575 Backlit Console W/Fuse (1-36 Row)
- (1)A7851 Planter Harness W/Dust Caps (12 Row)
- (12)A10901 Seed Tube W/Sensor
- (1)A6147 Sensor And Mounting Package
- (1)A7859 MDS Adapter
- (2)A8143 50 Pc. Pkg. (D1512) Tie Straps

### KPM II Monitor Package, 12 Row - 700-05101 (With Magnetic Distance Sensor)

#### Models 3140 Stack Folding

- (1)IS628 Instructions
- (1)IS539 Quick Reference Guide
- (1)A10575 Backlit Console W/Fuse (1-36 Row)
- (2)A7849 Extension Harness W/Female Connectors, 15'
- (1)A7850 Planter Harness W/Dust Caps (8 Row)
- (2)A8021 Planter Harness W/Dust Caps (4 Row)
- (12)A10901 Seed Tube W/Sensor
- (1)A6147 Sensor And Mounting Package
- (1)A7859 MDS Adapter
- (1)A8128 Drill Shaft Sensor Mounting Kit
- (1)A8135 Drill Shaft Rotation Sensor Kit
- (2)A8143 50 Pc. Pkg. (D1512) Tie Straps

### KPM II Monitor Package, 12 Row - 700-05122 (With Radar Distance Sensor)

#### Models 3120 Vertical Folding And 3200

- (1)IS628 Instructions
- (1)IS539 Quick Reference Guide
- (1)A10575 Backlit Console W/Fuse (1-36 Row)
- (1)A7851 Planter Harness W/Dust Caps (12 Row)
- (12)A10901 Seed Tube W/Sensor
- (1)A7858 Radar Sensor
- (1)A8128 Drill Shaft Sensor Mounting Kit
- (1)A8135 Drill Shaft Rotation Sensor Kit
- (1)A8026 Radar Pipe/Mounting Bracket Package
- (2)A8143 50 Pc. Pkg. (D1512) Tie Straps

**KPM II Monitor Package, 12 Row - 700-05104  
(With Radar Distance Sensor)**

**Model 3140 Stack Folding**

- 1)IS628 Instructions
- (1)IS539 Quick Reference Guide
- (1)A10575 Backlit Console W/Fuse (1-36 Row)
- (2)A7849 Extension Harness W/Female Connectors, 15'
- (1)A7850 Planter Harness W/Dust Caps (8 Row)
- (2)A8021 Planter Harness W/Dust Caps (4 Row)
- (12)A10901 Seed Tube W/Sensor
- (1)A7858 Radar Gun
- (1)A8128 Drill Shaft Sensor Mounting Kit
- (1)A8135 Drill Shaft Rotation Sensor Kit
- (2)A8143 50 Pc. Pkg. (D1512) Tie Straps
- (1)A8026 Radar Sensor

**KPM II Monitor Package, 12 Row - 700-05131  
(With Radar Distance Sensor)**

**Model 3400**

- (1)IS628 Instructions
- (1)IS539 Quick Reference Guide
- (1)A10575 Backlit Console W/Fuse (1-36 Row)
- (1)A7851 Planter Harness W/Dust Caps (12 Row)
- (12)A10901 Seed Tube W/Sensor
- (1)A7858 Radar Sensor
- (1)A8026 Radar Pipe/Mounting Bracket Package
- (2)A8143 50 Pc. Pkg. (D1512) Tie Straps

**KPM II Monitor Package, 12 Row - 700-05112  
(With Radar Distance Sensor)**

**Models 3600 And 3650**

- (1)IS628 Instructions
- (1)IS539 Quick Reference Guide
- (1)A10575 Backlit Console W/Fuse (1-36 Row)
- (1)A7851 Planter Harness W/Dust Caps (12 Row)
- (12)A10901 Seed Tube W/Sensor
- (1)A7858 Radar Sensor
- (1)A8128 Drill Shaft Sensor Mounting Kit
- (1)A8135 Drill Shaft Rotation Sensor Kit
- (1)A8026 Radar Pipe/Mounting Bracket Package
- (2)A8143 50 Pc. Pkg. (D1512) Tie Straps

**12 ROW SIZES (EdgeVac® Seed Metering)**

**KPM I Monitor Package, 12 Row - 700-05219**

**Model 3140 Stack Folding**

- (1)IS628 Instructions
- (1)IS448 Quick Reference Guide
- (1)A10570 Backlit Console W/Fuse (1-36 Row)
- (2)A7849 Extension Harness W/Female Connectors, 15'
- (1)A7850 Planter Harness W/Dust Caps (8 Row)
- (2)A8021 Planter Harness W/Dust Caps (4 Row)
- (12)A10142 Seed Tube W/Sensor
- (2)A8143 50 Pc. Pkg. (D1512) Tie Straps

**KPM I Monitor Package, 12 Row - 700-05227**

**Models 3200, 3400, 3600 And 3650**

- (1)IS628 Instructions
- (1)IS448 Quick Reference Guide
- (1)A10570 Backlit Console W/Fuse (1-36 Row)
- (1)A7851 Planter Harness W/Dust Caps (12 Row)
- (12)A10142 Seed Tube W/Sensor
- (2)A8143 50 Pc. Pkg. (D1512) Tie Straps

**KPM II Monitor Package, 12 Row - 700-05229  
(With Magnetic Distance Sensor)**

**Models 3200, 3600 And 3650**

- (1)IS628 Instructions
- (1)IS539 Quick Reference Guide
- (1)A10575 Backlit Console W/Fuse (1-36 Row)
- (1)A7851 Planter Harness W/Dust Caps (12 Row)
- (12)A10142 Seed Tube W/Sensor
- (1)A6147 Sensor And Mounting Package
- (1)A7859 MDS Adapter
- (1)A8128 Drill Shaft Sensor Mounting Kit
- (1)A8135 Drill Shaft Rotation Sensor Kit
- (2)A8143 50 Pc. Pkg. (D1512) Tie Straps

**KPM II Monitor Package, 12 Row - 700-05244  
(With Magnetic Distance Sensor)**

**Model 3400**

- (1)IS628 Instructions
- (1)IS539 Quick Reference Guide
- (1)A10575 Backlit Console W/Fuse (1-36 Row)
- (1)A7851 Planter Harness W/Dust Caps (12 Row)
- (12)A10142 Seed Tube W/Sensor
- (1)A6147 Sensor And Mounting Package
- (1)A7859 MDS Adapter
- (2)A8143 50 Pc. Pkg. (D1512) Tie Straps

**KPM II Monitor Package, 12 Row - 700-05222  
(With Magnetic Distance Sensor)**

**Models 3140 Stack Folding**

- (1)IS628 Instructions
- (1)IS539 Quick Reference Guide
- (1)A10575 Backlit Console W/Fuse (1-36 Row)
- (2)A7849 Extension Harness W/Female Connectors, 15'
- (1)A7850 Planter Harness W/Dust Caps (8 Row)
- (2)A8021 Planter Harness W/Dust Caps (4 Row)
- (12)A10142 Seed Tube W/Sensor
- (1)A6147 Sensor And Mounting Package
- (1)A7859 MDS Adapter
- (1)A8128 Drill Shaft Sensor Mounting Kit
- (1)A8135 Drill Shaft Rotation Sensor Kit
- (2)A8143 50 Pc. Pkg. (D1512) Tie Straps

**KPM II Monitor Package, 12 Row - 700-05225  
(With Radar Distance Sensor)**

**Model 3140 Stack Folding**

- (1)IS628 Instructions
- (1)IS539 Quick Reference Guide
- (1)A10575 Backlit Console W/Fuse (1-36 Row)
- (2)A7849 Extension Harness W/Female Connectors, 15'
- (1)A7850 Planter Harness W/Dust Caps (8 Row)
- (2)A8021 Planter Harness W/Dust Caps (4 Row)
- (12)A10142 Seed Tube W/Sensor
- (1)A7858 Radar Gun
- (1)A8128 Drill Shaft Sensor Mounting Kit
- (1)A8135 Drill Shaft Rotation Sensor Kit
- (2)A8143 50 Pc. Pkg. (D1512) Tie Straps
- (1)A8026 Radar Sensor

**KPM II Monitor Package, 12 Row - 700-05245  
(With Radar Distance Sensor)**

**Model 3400**

- (1)IS628 Instructions
- (1)IS539 Quick Reference Guide
- (1)A10575 Backlit Console W/Fuse (1-36 Row)
- (1)A7851 Planter Harness W/Dust Caps (12 Row)
- (12)A10142 Seed Tube W/Sensor
- (1)A7858 Radar Sensor
- (1)A8026 Radar Pipe/Mounting Bracket Package
- (2)A8143 50 Pc. Pkg. (D1512) Tie Straps

**KPM II Monitor Package, 12 Row - 700-05231  
(With Radar Distance Sensor)**

**Models 3200, 3600 And 3650**

- (1)IS628 Instructions
- (1)IS539 Quick Reference Guide
- (1)A10575 Backlit Console W/Fuse (1-36 Row)
- (1)A7851 Planter Harness W/Dust Caps (12 Row)
- (12)A10142 Seed Tube W/Sensor
- (1)A7858 Radar Sensor
- (1)A8128 Drill Shaft Sensor Mounting Kit
- (1)A8135 Drill Shaft Rotation Sensor Kit
- (1)A8026 Radar Pipe/Mounting Bracket Package
- (2)A8143 50 Pc. Pkg. (D1512) Tie Straps

## **16 ROW SIZES (Mechanical Seed Metering)**

### **KPM I Monitor Package, 16 Row - 700-05125**

#### **Model 3700**

- (1)IS628 Instructions
- (1)IS448 Quick Reference Guide
- (1)A10570 Backlit Console W/Fuse (1-36 Row)
- (2)A7850 Planter Harness W/Dust Caps (8 Row)
- (16)A10901 Seed Tube W/Sensor
- (3)A8143 50 Pc. Pkg. (D1512) Tie Straps

### **KPM I Monitor Package, 16 Row - 700-05099**

#### **Model 3140 Stack Folding**

- (1)IS628 Instructions
- (1)IS448 Quick Reference Guide
- (1)A10570 Backlit Console W/Fuse (1-36 Row)
- (2)A7849 Extension Harness W/Female Connectors, 15'
- (1)A7851 Planter Harness W/Dust Caps (12 Row)
- (2)A8021 Planter Harness W/Dust Caps (4 Row)
- (16)A10901 Seed Tube W/Sensor
- (3)A8143 50 Pc. Pkg. (D1512) Tie Straps

### **KPM I Monitor Package, 16 Row - 700-05109**

#### **Models 3600 And 3650**

- (1)IS628 Instructions
- (1)IS448 Quick Reference Guide
- (1)A10570 Backlit Console W/Fuse (1-36 Row)
- (1)A7852 Planter Harness W/Dust Caps (16 Row)
- (16)A10901 Seed Tube W/Sensor
- (3)A8143 50 Pc. Pkg. (D1512) Tie Straps

### **KPM II Monitor Package, 16 Row - 700-05111 (With Magnetic Distance Sensor)**

#### **Models 3600 And 3650**

- (1)IS628 Instructions
- (1)IS539 Quick Reference Guide
- (1)A10575 Backlit Console W/Fuse (1-36 Row)
- (1)A7852 Planter Harness W/Dust Caps (16 Row)
- (16)A10901 Seed Tube W/Sensor
- (1)A6147 Sensor And Mounting Package
- (1)A7859 MDS Adapter
- (1)A8128 Drill Shaft Sensor Mounting Kit
- (1)A8135 Drill Shaft Rotation Sensor Kit
- (3)A8143 50 Pc. Pkg. (D1512) Tie Straps

### **KPM II Monitor Package, 16 Row - 700-05126 (With Magnetic Distance Sensor)**

#### **Model 3700**

- (1)IS628 Instructions
- (1)IS539 Quick Reference Guide
- (1)A10575 Backlit Console W/Fuse (1-36 Row)
- (2)A7850 Planter Harness W/Dust Caps (8 Row)
- (16)A10901 Seed Tube W/Sensor
- (1)A6147 Sensor And Mounting Package
- (1)A7859 MDS Adapter
- (1)A8128 Drill Shaft Sensor Mounting Kit
- (1)A8135 Drill Shaft Rotation Sensor Kit
- (3)A8143 50 Pc. Pkg. (D1512) Tie Straps

### **KPM II Monitor Package, 16 Row - 700-05102 (With Magnetic Distance Sensor)**

#### **Model 3140 Stack Folding**

- (1)IS628 Instructions
- (1)IS539 Quick Reference Guide
- (1)A10575 Backlit Console W/Fuse (1-36 Row)
- (2)A7849 Extension Harness W/Female Connectors, 15'
- (1)A7851 Planter Harness W/Dust Caps (12 Row)
- (2)A8021 Planter Harness W/Dust Caps (4 Row)
- (16)A10901 Seed Tube W/Sensor
- (1)A6147 Sensor And Mounting Package
- (1)A7859 MDS Adapter
- (1)A8128 Drill Shaft Sensor Mounting Kit
- (1)A8135 Drill Shaft Rotation Sensor Kit
- (3)A8143 50 Pc. Pkg. (D1512) Tie Straps

### **KPM II Monitor Package, 16 Row - 700-05113 (With Radar Distance Sensor)**

#### **Models 3600 And 3650**

- (1)IS628 Instructions
- (1)IS539 Quick Reference Guide
- (1)A10575 Backlit Console W/Fuse (1-36 Row)
- (1)A7852 Planter Harness W/Dust Caps (16 Row)
- (16)A10901 Seed Tube W/Sensor
- (1)A7858 Radar Sensor
- (1)A8128 Drill Shaft Sensor Mounting Kit
- (1)A8135 Drill Shaft Rotation Sensor Kit
- (1)A8026 Radar Pipe/Mounting Bracket Package
- (3)A8143 50 Pc. Pkg. (D1512) Tie Straps

**KPM II Monitor Package, 16 Row - 700-05127  
(With Radar Distance Sensor)**

**Model 3700**

- (1)IS628 Instructions
- (1)IS539 Quick Reference Guide
- (1)A10575 Backlit Console W/Fuse (1-36 Row)
- (2)A7850 Planter Harness W/Dust Caps (8 Row)
- (16)A10901 Seed Tube W/Sensor
- (1)A7858 Radar Sensor
- (1)A8128 Drill Shaft Sensor Mounting Kit
- (1)A8135 Drill Shaft Rotation Sensor Kit
- (1)A8026 Radar Pipe/Mounting Bracket Package
- (3)A8143 50 Pc. Pkg. (D1512) Tie Straps

**KPM II Monitor Package, 16 Row - 700-05105  
(With Radar Distance Sensor)**

**Model 3140 Stack Folding**

- (1)IS628 Instructions
- (1)IS539 Quick Reference Guide
- (1)A10575 Backlit Console W/Fuse (1-36 Row)
- (2)A7849 Extension Harness W/Female Connectors, 15'
- (1)A7851 Planter Harness W/Dust Caps (12 Row)
- (2)A8021 Planter Harness W/Dust Caps (4 Row)
- (16)A10901 Seed Tube W/Sensor
- (1)A7858 Radar Sensor
- (1)A8128 Drill Shaft Sensor Mounting Kit
- (1)A8135 Drill Shaft Rotation Sensor Kit
- (1)A8026 Radar Pipe/Mounting Bracket Package
- (3)A8143 50 Pc. Pkg. (D1512) Tie Straps

**16 ROW SIZES (EdgeVac® Seed Metering)**

**KPM I Monitor Package, 16 Row - 700-05235**

**Model 3700**

- (1)IS628 Instructions
- (1)IS448 Quick Reference Guide
- (1)A10570 Backlit Console W/Fuse (1-36 Row)
- (2)A7850 Planter Harness W/Dust Caps (8 Row)
- (16)A10142 Seed Tube W/Sensor
- (3)A8143 50 Pc. Pkg. (D1512) Tie Straps

**KPM I Monitor Package, 16 Row - 700-05220**

**Model 3140 Stack Folding**

- (1)IS628 Instructions
- (1)IS448 Quick Reference Guide
- (1)A10570 Backlit Console W/Fuse (1-36 Row)
- (2)A7849 Extension Harness W/Female Connectors, 15'
- (1)A7851 Planter Harness W/Dust Caps (12 Row)
- (2)A8021 Planter Harness W/Dust Caps (4 Row)
- (16)A10142 Seed Tube W/Sensor
- (3)A8143 50 Pc. Pkg. (D1512) Tie Straps

**KPM I Monitor Package, 16 Row - 700-05228**

**Models 3600 And 3650**

- (1)IS628 Instructions
- (1)IS448 Quick Reference Guide
- (1)A10570 Backlit Console W/Fuse (1-36 Row)
- (1)A7852 Planter Harness W/Dust Caps (16 Row)
- (16)A10142 Seed Tube W/Sensor
- (3)A8143 50 Pc. Pkg. (D1512) Tie Straps

**KPM II Monitor Package, 16 Row - 700-05230  
(With Magnetic Distance Sensor)**

**Models 3600 And 3650**

- (1)IS628 Instructions
- (1)IS539 Quick Reference Guide
- (1)A10575 Backlit Console W/Fuse (1-36 Row)
- (1)A7852 Planter Harness W/Dust Caps (16 Row)
- (16)A10142 Seed Tube W/Sensor
- (1)A6147 Sensor And Mounting Package
- (1)A7859 MDS Adapter
- (1)A8128 Drill Shaft Sensor Mounting Kit
- (1)A8135 Drill Shaft Rotation Sensor Kit
- (3)A8143 50 Pc. Pkg. (D1512) Tie Straps

**KPM II Monitor Package, 16 Row - 700-05238  
(With Magnetic Distance Sensor)**

**Model 3700**

- (1)IS628 Instructions
- (1)IS539 Quick Reference Guide
- (1)A10575 Backlit Console W/Fuse (1-36 Row)
- (2)A7850 Planter Harness W/Dust Caps (8 Row)
- (16)A10142 Seed Tube W/Sensor
- (1)A6147 Sensor And Mounting Package
- (1)A7859 MDS Adapter
- (1)A8128 Drill Shaft Sensor Mounting Kit
- (1)A8135 Drill Shaft Rotation Sensor Kit
- (3)A8143 50 Pc. Pkg. (D1512) Tie Straps

**KPM II Monitor Package, 16 Row - 700-05223  
(With Magnetic Distance Sensor)**

**Model 3140 Stack Folding**

- (1)IS628 Instructions
- (1)IS539 Quick Reference Guide
- (1)A10575 Backlit Console W/Fuse (1-36 Row)
- (2)A7849 Extension Harness W/Female Connectors, 15'
- (1)A7851 Planter Harness W/Dust Caps (12 Row)
- (2)A8021 Planter Harness W/Dust Caps (4 Row)
- (16)A10142 Seed Tube W/Sensor
- (1)A6147 Sensor And Mounting Package
- (1)A7859 MDS Adapter
- (1)A8128 Drill Shaft Sensor Mounting Kit
- (1)A8135 Drill Shaft Rotation Sensor Kit
- (3)A8143 50 Pc. Pkg. (D1512) Tie Straps

**KPM II Monitor Package, 16 Row - 700-05232  
(With Radar Distance Sensor)**

**Models 3600 And 3650**

- (1)IS628 Instructions
- (1)IS539 Quick Reference Guide
- (1)A10575 Backlit Console W/Fuse (1-36 Row)
- (1)A7852 Planter Harness W/Dust Caps (16 Row)
- (16)A10142 Seed Tube W/Sensor
- (1)A7858 Radar Sensor
- (1)A8128 Drill Shaft Sensor Mounting Kit
- (1)A8135 Drill Shaft Rotation Sensor Kit
- (1)A8026 Radar Pipe/Mounting Bracket Package
- (3)A8143 50 Pc. Pkg. (D1512) Tie Straps

**KPM II Monitor Package, 16 Row - 700-05241  
(With Radar Distance Sensor)**

**Model 3700**

- (1)IS628 Instructions
- (1)IS539 Quick Reference Guide
- (1)A10575 Backlit Console W/Fuse (1-36 Row)
- (2)A7850 Planter Harness W/Dust Caps (8 Row)
- (16)A10142 Seed Tube W/Sensor
- (1)A7858 Radar Sensor
- (1)A8128 Drill Shaft Sensor Mounting Kit
- (1)A8135 Drill Shaft Rotation Sensor Kit
- (1)A8026 Radar Pipe/Mounting Bracket Package
- (3)A8143 50 Pc. Pkg. (D1512) Tie Straps

**KPM II Monitor Package, 16 Row - 700-05226  
(With Radar Distance Sensor)**

**Model 3140 Stack Folding**

- (1)IS628 Instructions
- (1)IS539 Quick Reference Guide
- (1)A10575 Backlit Console W/Fuse (1-36 Row)
- (2)A7849 Extension Harness W/Female Connectors, 15'
- (1)A7851 Planter Harness W/Dust Caps (12 Row)
- (2)A8021 Planter Harness W/Dust Caps (4 Row)
- (16)A10142 Seed Tube W/Sensor
- (1)A7858 Radar Sensor
- (1)A8128 Drill Shaft Sensor Mounting Kit
- (1)A8135 Drill Shaft Rotation Sensor Kit
- (1)A8026 Radar Pipe/Mounting Bracket Package
- (3)A8143 50 Pc. Pkg. (D1512) Tie Straps

## 24 ROW SIZES (Mechanical Seed Metering)

### KPM I Monitor Package, 24 Row - 700-05128

#### Model 3700

- (1)IS628 Instructions
- (1)IS448 Quick Reference Guide
- (1)A10570 Backlit Console W/Fuse (1-36 Row)
- (2)A7851 Planter Harness W/Dust Caps (12 Row)
- (24)A10901 Seed Tube W/Sensor
- (3)A8143 50 Pc. Pkg. (D1512) Tie Straps

### KPM II Monitor Package, 24 Row - 700-05132 (With Magnetic Distance Sensor)

#### Model 3700

- (1)IS628 Instructions
- (1)IS539 Quick Reference Guide
- (1)A10575 Backlit Console W/Fuse (1-36 Row)
- (2)A7851 Planter Harness W/Dust Caps (12 Row)
- (24)A10901 Seed Tube W/Sensor
- (1)A6147 Sensor And Mounting Package
- (1)A7859 MDS Adapter
- (1)A8128 Drill Shaft Sensor Mounting Kit
- (1)A8135 Drill Shaft Rotation Sensor Kit
- (1)A9857 SMM Backlit Monitor
- (1)A7853 Junction Y-Harness W/Dust Cap
- (3)A8143 50 Pc. Pkg. (D1512) Tie Straps

### KPM II Monitor Package, 24 Row - 700-05136 (With Magnetic Distance Sensor)

#### Model 3800

- (1)IS628 Instructions
- (1)IS539 Quick Reference Guide
- (1)A10575 Backlit Console W/Fuse (1-36 Row)
- (2)A7851 Planter Harness W/Dust Caps (12 Row)
- (1)A8022 Planter Harness W/Dust Caps (6 Row)
- (24)A10901 Seed Tube W/Sensor
- (1)A6147 Sensor And Mounting Package
- (1)A7859 MDS Adapter
- (2)A8128 Drill Shaft Sensor Mounting Kit
- (2)A8135 Drill Shaft Rotation Sensor Kit
- (1)A9857 SMM Backlit Monitor
- (1)A7849 Extension Harness W/Female Connectors, 15'
- (4)A8143 50 Pc. Pkg. (D1512) Tie Straps
- (1)A7853 Junction Y-Harness W/Dust Cap

### KPM II Monitor Package, 24 Row - 700-05133 (With Radar Distance Sensor)

#### Model 3700

- (1)IS628 Instructions
- (1)IS539 Quick Reference Guide
- (1)A10575 Backlit Console W/Fuse (1-36 Row)
- (2)A7851 Planter Harness W/Dust Caps (12 Row)
- (24)A10901 Seed Tube W/Sensor
- (1)A7858 Radar Sensor
- (1)A8128 Drill Shaft Sensor Mounting Kit
- (1)A8135 Drill Shaft Rotation Sensor Kit
- (1)A8026 Radar Pipe/Mounting Bracket Package
- (1)A9857 SMM Backlit Monitor
- (1)A7853 Junction Y-Harness W/Dust Cap
- (3)A8143 50 Pc. Pkg. (D1512) Tie Straps

### KPM II Monitor Package, 24 Row - 700-05137 (With Radar Distance Sensor)

#### Model 3800

- (1)IS628 Instructions
- (1)IS539 Quick Reference Guide
- (1)A10575 Backlit Console W/Fuse (1-36 Row)
- (2)A7851 Planter Harness W/Dust Caps (12 Row)
- (1)A8022 Planter Harness W/Dust Caps (6 Row)
- (24)A10901 Seed Tube W/Sensor
- (1)A7858 Radar Sensor
- (2)A8128 Drill Shaft Sensor Mounting Kit
- (2)A8135 Drill Shaft Rotation Sensor Kit
- (1)A8026 Radar Pipe/Mounting Bracket Package
- (1)A9857 SMM Backlit Monitor
- (1)A7849 Extension Harness W/Female Connectors, 15'
- (4)A8143 50 Pc. Pkg. (D1512) Tie Straps
- (1)A7853 Junction Y-Harness W/Dust Cap

## 24 ROW SIZES (EdgeVac® Seed Metering)

### KPM I Monitor Package, 24 Row - 700-05236

#### Model 3700

- (1)IS628 Instructions
- (1)IS448 Quick Reference Guide
- (1)A10570 Backlit Console W/Fuse (1-36 Row)
- (2)A7851 Planter Harness W/Dust Caps (12 Row)
- (24)A10142 Seed Tube W/Sensor
- (3)A8143 50 Pc. Pkg. (D1512) Tie Straps

### KPM II Monitor Package, 24 Row - 700-05239

#### (With Magnetic Distance Sensor)

#### Model 3700

- (1)IS628 Instructions
- (1)IS539 Quick Reference Guide
- (1)A10575 Backlit Console W/Fuse (1-36 Row)
- (2)A7851 Planter Harness W/Dust Caps (12 Row)
- (24)A10142 Seed Tube W/Sensor
- (1)A6147 Sensor And Mounting Package
- (1)A7859 MDS Adapter
- (1)A8128 Drill Shaft Sensor Mounting Kit
- (1)A8135 Drill Shaft Rotation Sensor Kit
- (1)A9857 SMM Backlit Monitor
- (1)A7853 Junction Y-Harness W/Dust Cap
- (3)A8143 50 Pc. Pkg. (D1512) Tie Straps

### KPM II Monitor Package, 24 Row - 700-05246

#### (With Magnetic Distance Sensor)

#### Model 3800

- (1)IS628 Instructions
- (1)IS539 Quick Reference Guide
- (1)A10575 Backlit Console W/Fuse (1-36 Row)
- (2)A7851 Planter Harness W/Dust Caps (12 Row)
- (1)A8022 Planter Harness W/Dust Caps (6 Row)
- (24)A10142 Seed Tube W/Sensor
- (1)A6147 Sensor And Mounting Package
- (1)A7859 MDS Adapter
- (2)A8128 Drill Shaft Sensor Mounting Kit
- (2)A8135 Drill Shaft Rotation Sensor Kit
- (1)A9857 SMM Backlit Monitor
- (1)A7849 Extension Harness W/Female Connectors, 15'
- (4)A8143 50 Pc. Pkg. (D1512) Tie Straps
- (1)A7853 Junction Y-Harness W/Dust Cap

### KPM II Monitor Package, 24 Row - 700-05242

#### (With Radar Distance Sensor)

#### Model 3700

- (1)IS628 Instructions
- (1)IS539 Quick Reference Guide
- (1)A10575 Backlit Console W/Fuse (1-36 Row)
- (2)A7851 Planter Harness W/Dust Caps (12 Row)
- (24)A10142 Seed Tube W/Sensor
- (1)A7858 Radar Sensor
- (1)A8128 Drill Shaft Sensor Mounting Kit
- (1)A8135 Drill Shaft Rotation Sensor Kit
- (1)A8026 Radar Pipe/Mounting Bracket Package
- (1)A9857 SMM Backlit Monitor
- (1)A7853 Junction Y-Harness W/Dust Cap
- (3)A8143 50 Pc. Pkg. (D1512) Tie Straps

### KPM II Monitor Package, 24 Row - 700-05247

#### (With Radar Distance Sensor)

#### Model 3800

- (1)IS628 Instructions
- (1)IS539 Quick Reference Guide
- (1)A10575 Backlit Console W/Fuse (1-36 Row)
- (2)A7851 Planter Harness W/Dust Caps (12 Row)
- (1)A8022 Planter Harness W/Dust Caps (6 Row)
- (24)A10142 Seed Tube W/Sensor
- (1)A7858 Radar Sensor
- (2)A8128 Drill Shaft Sensor Mounting Kit
- (2)A8135 Drill Shaft Rotation Sensor Kit
- (1)A8026 Radar Pipe/Mounting Bracket Package
- (1)A9857 SMM Backlit Monitor
- (1)A7849 Extension Harness W/Female Connectors, 15'
- (4)A8143 50 Pc. Pkg. (D1512) Tie Straps
- (1)A7853 Junction Y-Harness W/Dust Cap

## 32 ROW SIZE (Mechanical Seed Metering)

### KPM II Monitor Package, 32 Row - 700-05138 (With Magnetic Distance Sensor)

#### Model 3800

- (1)IS628 Instructions
- (1)IS539 Quick Reference Guide
- (1)A10575 Backlit Console W/Fuse (1-36 Row)
- (2)A7852 Planter Harness W/Dust Caps (16 Row)
- (1)A8022 Planter Harness W/Dust Caps (6 Row)
- (32)A10901 Seed Tube W/Sensor
- (1)A6147 Sensor And Mounting Package
- (1)A7859 MDS Adapter
- (2)A8128 Drill Shaft Sensor Mounting Kit
- (2)A8135 Drill Shaft Rotation Sensor Kit
- (1)A9857 SMM Backlit Monitor
- (1)A7849 Extension Harness W/Female Connectors, 15'
- (5)A8143 50 Pc. Pkg. (D1512) Tie Straps
- (1)A7853 Junction Y-Harness W/Dust Cap

### KPM II Monitor Package, 32 Row - 700-05139 (With Radar Distance Sensor)

#### Model 3800

- (1)IS628 Instructions
- (1)IS539 Quick Reference Guide
- (1)A10575 Backlit Console W/Fuse (1-36 Row)
- (2)A7852 Planter Harness W/Dust Caps (16 Row)
- (1)A8022 Planter Harness W/Dust Caps (6 Row)
- (32)A10901 Seed Tube W/Sensor
- (1)A7858 Radar Sensor
- (2)A8128 Drill Shaft Sensor Mounting Kit
- (2)A8135 Drill Shaft Rotation Sensor Kit
- (1)A8026 Radar Pipe/Mounting Bracket Package
- (1)A9857 SMM Backlit Monitor
- (1)A7849 Extension Harness W/Female Connectors, 15'
- (5)A8143 50 Pc. Pkg. (D1512) Tie Straps
- (1)A7853 Junction Y-Harness W/Dust Cap

## 32 ROW SIZE (EdgeVac® Seed Metering)

### KPM II Monitor Package, 32 Row - 700-05248 (With Magnetic Distance Sensor)

#### Model 3800

- (1)IS628 Instructions
- (1)IS539 Quick Reference Guide
- (1)A10575 Backlit Console W/Fuse (1-36 Row)
- (2)A7852 Planter Harness W/Dust Caps (16 Row)
- (1)A8022 Planter Harness W/Dust Caps (6 Row)
- (32)A10142 Seed Tube W/Sensor
- (1)A6147 Sensor And Mounting Package
- (1)A7859 MDS Adapter
- (2)A8128 Drill Shaft Sensor Mounting Kit
- (2)A8135 Drill Shaft Rotation Sensor Kit
- (1)A9857 SMM Backlit Monitor
- (1)A7849 Extension Harness W/Female Connectors, 15'
- (5)A8143 50 Pc. Pkg. (D1512) Tie Straps
- (1)A7853 Junction Y-Harness W/Dust Cap

### KPM II Monitor Package, 32 Row - 700-05249 (With Radar Distance Sensor)

#### Model 3800

- (1)IS628 Instructions
- (1)IS539 Quick Reference Guide
- (1)A10575 Backlit Console W/Fuse (1-36 Row)
- (2)A7852 Planter Harness W/Dust Caps (16 Row)
- (1)A8022 Planter Harness W/Dust Caps (6 Row)
- (32)A10142 Seed Tube W/Sensor
- (1)A7858 Radar Sensor
- (2)A8128 Drill Shaft Sensor Mounting Kit
- (2)A8135 Drill Shaft Rotation Sensor Kit
- (1)A8026 Radar Pipe/Mounting Bracket Package
- (1)A9857 SMM Backlit Monitor
- (1)A7849 Extension Harness W/Female Connectors, 15'
- (5)A8143 50 Pc. Pkg. (D1512) Tie Straps
- (1)A7853 Junction Y-Harness W/Dust Cap

### 36 ROW SIZES (Mechanical Seed Metering)

#### KPM I Monitor Package, 36 Row - 700-05129

##### Model 3700

- (1)IS628 Instructions
- (1)IS448 Quick Reference Guide
- (1)A10570 Backlit Console W/Fuse (1-36 Row)
- (2)A8050 Planter Harness W/Dust Caps (18 Row)
- (36)A10901 Seed Tube W/Sensor
- (4)A8143 50 Pc. Pkg. (D1512) Tie Straps

#### KPM II Monitor Package, 36 Row - 700-05134

#### (With Magnetic Distance Sensor)

##### Model 3700

- (1)IS628 Instructions
- (1)IS539 Quick Reference Guide
- (1)A10575 Backlit Console W/Fuse (1-36 Row)
- (2)A8050 Planter Harness W/Dust Caps (18 Row)
- (36)A10901 Seed Tube W/Sensor
- (1)A6147 Sensor And Mounting Package
- (1)A7859 MDS Adapter
- (1)A8128 Drill Shaft Sensor Mounting Kit
- (1)A8135 Drill Shaft Rotation Sensor Kit
- (1)A9857 SMM Backlit Monitor
- (1)A7853 Junction Y-Harness W/Dust Cap
- (4)A8143 50 Pc. Pkg. (D1512) Tie Straps

#### KPM II Monitor Package, 36 Row - 700-05140

#### (With Magnetic Distance Sensor)

##### Model 3800

- (1)IS628 Instructions
- (1)IS539 Quick Reference Guide
- (1)A10575 Backlit Console W/Fuse (1-36 Row)
- (2)A7852 Planter Harness W/Dust Caps (16 Row)
- (1)A8022 Planter Harness W/Dust Caps (6 Row)
- (36)A10901 Seed Tube W/Sensor
- (1)A6147 Sensor And Mounting Package
- (1)A7859 MDS Adapter
- (2)A8128 Drill Shaft Sensor Mounting Kit
- (2)A8135 Drill Shaft Rotation Sensor Kit
- (1)A9857 SMM Backlit Monitor
- (1)A7849 Extension Harness W/Female Connectors, 15'
- (5)A8143 50 Pc. Pkg. (D1512) Tie Straps
- (1)A7853 Junction Y-Harness W/Dust Cap

#### KPM II Monitor Package, 36 Row - 700-05135

#### (With Radar Distance Sensor)

##### Model 3700

- (1)IS628 Instructions
- (1)IS539 Quick Reference Guide
- (1)A10575 Backlit Console W/Fuse (1-36 Row)
- (2)A8050 Planter Harness W/Dust Caps (18 Row)
- (36)A10901 Seed Tube W/Sensor
- (1)A7858 Radar Sensor
- (1)A8128 Drill Shaft Sensor Mounting Kit
- (1)A8135 Drill Shaft Rotation Sensor Kit
- (1)A8026 Radar Pipe/Mounting Bracket Package
- (1)A9857 SMM Backlit Monitor
- (1)A7853 Junction Y-Harness W/Dust Cap
- (4)A8143 50 Pc. Pkg. (D1512) Tie Straps

#### KPM II Monitor Package, 36 Row - 700-05141

#### (With Radar Distance Sensor)

##### Model 3800

- (1)IS628 Instructions
- (1)IS539 Quick Reference Guide
- (1)A10575 Backlit Console W/Fuse (1-36 Row)
- (2)A7852 Planter Harness W/Dust Caps (16 Row)
- (1)A8022 Planter Harness W/Dust Caps (6 Row)
- (36)A10901 Seed Tube W/Sensor
- (1)A7858 Radar Sensor
- (2)A8128 Drill Shaft Sensor Mounting Kit
- (2)A8135 Drill Shaft Rotation Sensor Kit
- (1)A8026 Radar Pipe/Mounting Bracket Package
- (1)A9857 SMM Backlit Monitor
- (1)A7849 Extension Harness W/Female Connectors, 15'
- (5)A8143 50 Pc. Pkg. (D1512) Tie Straps
- (1)A7853 Junction Y-Harness W/Dust Cap

## 36 ROW SIZES (EdgeVac® Seed Metering)

### KPM I Monitor Package, 36 Row - 700-05237

#### Model 3700

- (1)IS628 Instructions
- (1)IS448 Quick Reference Guide
- (1)A10570 Backlit Console W/Fuse (1-36 Row)
- (2)A8050 Planter Harness W/Dust Caps (18 Row)
- (36)A10142 Seed Tube W/Sensor
- (4)A8143 50 Pc. Pkg. (D1512) Tie Straps

### KPM II Monitor Package, 36 Row - 700-05240 (With Magnetic Distance Sensor)

#### Model 3700

- (1)IS628 Instructions
- (1)IS539 Quick Reference Guide
- (1)A10575 Backlit Console W/Fuse (1-36 Row)
- (2)A8050 Planter Harness W/Dust Caps (18 Row)
- (36)A10142 Seed Tube W/Sensor
- (1)A6147 Sensor And Mounting Package
- (1)A7859 MDS Adapter
- (1)A8128 Drill Shaft Sensor Mounting Kit
- (1)A8135 Drill Shaft Rotation Sensor Kit
- (1)A9857 SMM Backlit Monitor
- (1)A7853 Junction Y-Harness W/Dust Cap
- (4)A8143 50 Pc. Pkg. (D1512) Tie Straps

### KPM II Monitor Package, 36 Row - 700-05250 (With Magnetic Distance Sensor)

#### Model 3800

- (1)IS628 Instructions
- (1)IS539 Quick Reference Guide
- (1)A10575 Backlit Console W/Fuse (1-36 Row)
- (2)A7852 Planter Harness W/Dust Caps (16 Row)
- (1)A8022 Planter Harness W/Dust Caps (6 Row)
- (36)A10142 Seed Tube W/Sensor
- (1)A6147 Sensor And Mounting Package
- (1)A7859 MDS Adapter
- (2)A8128 Drill Shaft Sensor Mounting Kit
- (2)A8135 Drill Shaft Rotation Sensor Kit
- (1)A9857 SMM Backlit Monitor
- (1)A7849 Extension Harness W/Female Connectors, 15'
- (5)A8143 50 Pc. Pkg. (D1512) Tie Straps
- (1)A7853 Junction Y-Harness W/Dust Cap

### KPM II Monitor Package, 36 Row - 700-05243 (With Radar Distance Sensor)

#### Model 3700

- (1)IS628 Instructions
- (1)IS539 Quick Reference Guide
- (1)A10575 Backlit Console W/Fuse (1-36 Row)
- (2)A8050 Planter Harness W/Dust Caps (18 Row)
- (36)A10142 Seed Tube W/Sensor
- (1)A7858 Radar Sensor
- (1)A8128 Drill Shaft Sensor Mounting Kit
- (1)A8135 Drill Shaft Rotation Sensor Kit
- (1)A8026 Radar Pipe/Mounting Bracket Package
- (1)A9857 SMM Backlit Monitor
- (1)A7853 Junction Y-Harness W/Dust Cap
- (4)A8143 50 Pc. Pkg. (D1512) Tie Straps

### KPM II Monitor Package, 36 Row - 700-05251 (With Radar Distance Sensor)

#### Model 3800

- (1)IS628 Instructions
- (1)IS539 Quick Reference Guide
- (1)A10575 Backlit Console W/Fuse (1-36 Row)
- (2)A7852 Planter Harness W/Dust Caps (16 Row)
- (1)A8022 Planter Harness W/Dust Caps (6 Row)
- (36)A10142 Seed Tube W/Sensor
- (1)A7858 Radar Sensor
- (2)A8128 Drill Shaft Sensor Mounting Kit
- (2)A8135 Drill Shaft Rotation Sensor Kit
- (1)A8026 Radar Pipe/Mounting Bracket Package
- (1)A9857 SMM Backlit Monitor
- (1)A7849 Extension Harness W/Female Connectors, 15'
- (5)A8143 50 Pc. Pkg. (D1512) Tie Straps
- (1)A7853 Junction Y-Harness W/Dust Cap

**INTERPLANT® MONITOR PACKAGES  
(Mechanical Seed Metering)**

**Interplant® Monitor Package,  
4 Row - 700-05114**

**Model 3000**

- (1)A8021 Planter Harness W/Dust Caps (4 Row)
- (3)A10901 Seed Tube W/Sensor
- (1)A7853 Junction Y-Harness W/Dust Cap
- (1)A8143 50 Pc. Pkg. (D1512) Tie Straps

**Interplant® Monitor Package,  
6 Row - 700-05115**

**Models 3000 And 3500**

- (1)A8021 Planter Harness W/Dust Caps (4 Row)
- (5)A10901 Seed Tube W/Sensor
- (1)A7853 Junction Y-Harness W/Dust Cap
- (2)A8143 50 Pc. Pkg. (D1512) Tie Straps

**Interplant® Monitor Package,  
8 Row - 700-05116**

**Models 3000, 3500 And 3600**

- (1)A8022 Planter Harness W/Dust Caps (6 Row)
- (7)A10901 Seed Tube W/Sensor
- (1)A7853 Junction Y-Harness W/Dust Cap
- (2)A8143 50 Pc. Pkg. (D1512) Tie Straps

**Interplant® Monitor Package,  
12 Row - 700-05117**

**Models 3400, 3600 And 3650**

- (1)A7851 Planter Harness W/Dust Caps (12 Row)
- (11)A10901 Seed Tube W/Sensor
- (1)A7853 Junction Y-Harness W/Dust Cap
- (2)A8143 50 Pc. Pkg. (D1512) Tie Straps

**Interplant® Monitor Package,  
16 Row - 700-05118**

**Models 3600 And 3650**

- (15)A10901 Seed Tube W/Sensor
- (1)A7853 Junction Y-Harness W/Dust Cap
- (1)A7852 Planter Harness W/Dust Caps (16 Row)
- (2)A8143 50 Pc. Pkg. (D1512) Tie Straps

**INTERPLANT® MONITOR PACKAGES  
(EdgeVac® Seed Metering)**

**Interplant® Monitor Package,  
4 Row - 700-05252**

**Model 3000**

- (1)A8021 Planter Harness W/Dust Caps (4 Row)
- (3)A10142 Seed Tube W/Sensor
- (1)A7853 Junction Y-Harness W/Dust Cap
- (1)A8143 50 Pc. Pkg. (D1512) Tie Straps

**Interplant® Monitor Package,  
6 Row - 700-05253**

**Models 3000 And 3500**

- (1)A8021 Planter Harness W/Dust Caps (4 Row)
- (5)A10142 Seed Tube W/Sensor
- (1)A7853 Junction Y-Harness W/Dust Cap
- (2)A8143 50 Pc. Pkg. (D1512) Tie Straps

**Interplant® Monitor Package,  
8 Row - 700-05254**

**Models 3000, 3500 And 3600**

- (1)A8022 Planter Harness W/Dust Caps (6 Row)
- (7)A10142 Seed Tube W/Sensor
- (1)A7853 Junction Y-Harness W/Dust Cap
- (2)A8143 50 Pc. Pkg. (D1512) Tie Straps

**Interplant® Monitor Package,  
12 Row - 700-05255**

**Models 3400, 3600 And 3650**

- (1)A7851 Planter Harness W/Dust Caps (12 Row)
- (11)A10142 Seed Tube W/Sensor
- (1)A7853 Junction Y-Harness W/Dust Cap
- (2)A8143 50 Pc. Pkg. (D1512) Tie Straps

**Interplant® Monitor Package,  
16 Row - 700-05256**

**Models 3600 And 3650**

- (15)A10142 Seed Tube W/Sensor
- (1)A7853 Junction Y-Harness W/Dust Cap
- (1)A7852 Planter Harness W/Dust Caps (16 Row)
- (2)A8143 50 Pc. Pkg. (D1512) Tie Straps

*KINZE®*, the *KINZE®* logo, *Econo-Fold®*, *Twin-Line®*, *Interplant®* and *EdgeVac®* are registered trademarks of KINZE Manufacturing, Inc.